

## How to Determine Current Levels of Grease and Solids in a Trapzilla Grease Interceptor:

Due to its unique design, Trapzilla is capable of retaining high quantities of grease in a compact footprint. Therefore, unlike traditional interceptors, Trapzilla can hold an extraordinarily high percentage of its volume in grease without losing separation efficiency. Follow the instructions below to determine levels of grease and solids.

1. Remove four nuts/washers securing the Solid Top Cover. Note the size of the unit which is marked on the cover by a metal plate.
2. Place a grease/sludge dipstick into the center of the Trapzilla, making sure that it goes through the hole in the horizontal baffle.
3. Once the dipstick has found its natural resting place at the lowest point in the conical shaped bottom, take the measurement.
4. Remove dipstick and compare grease/sludge levels to the corresponding unit in the charts below.

	Grease		Solids	
	Total Capacity (depth):	Ready to pump at (depth):	Total Capacity (height):	Ready to pump at (height):
TZ-1826	25"	20"	13.5"	10.75"
TZ-600	17"	13.75"	14"	12"
TZ-400	9.375"	7.5"	14"	12"
TZ-160	13"	10.5"	10"	8"

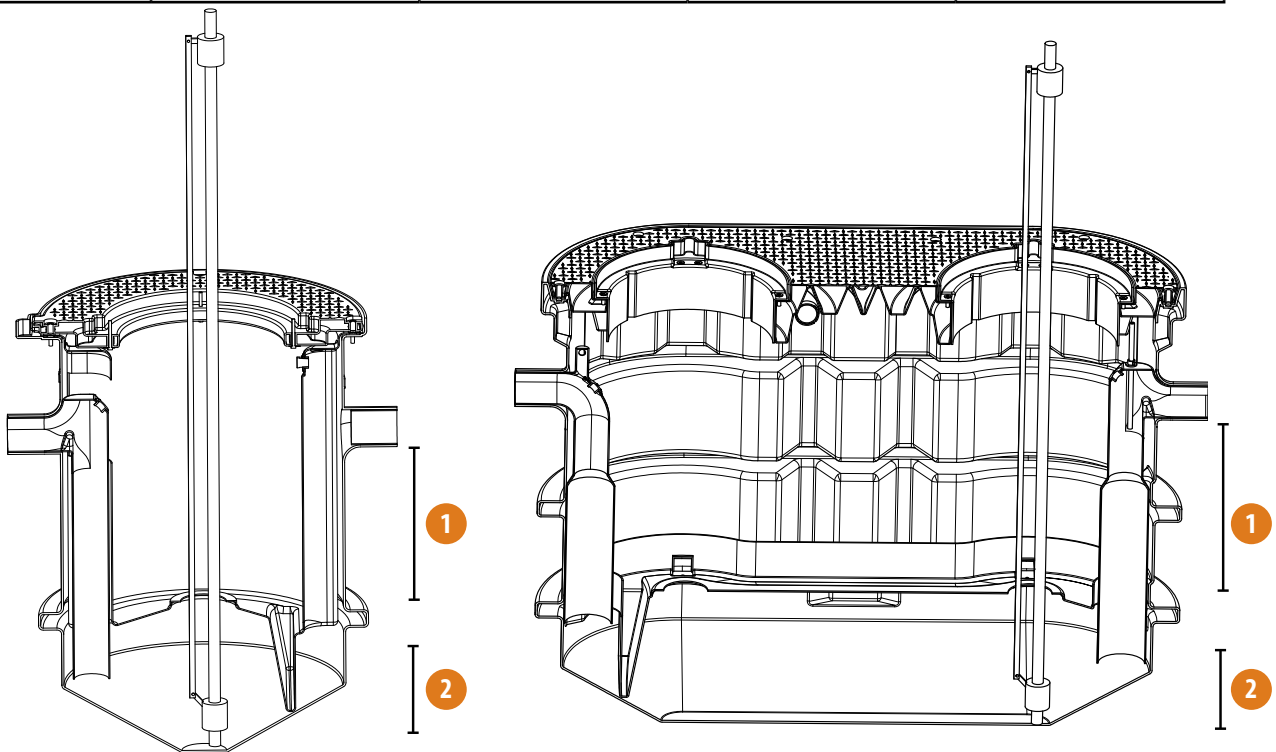

**1** Take grease measurement from top of liquid level downward and compare to chart above.

**2** Take solids/sludge measurement from bottom of unit upward and compare to chart above.

### How to Pump Out a Trapzilla Grease Interceptor:

Periodically, the Trapzilla® unit will need to be serviced which involves pumping out the accumulated grease & solids. Pumping frequency may be set at a regular interval by sewer district (every 30-90 days). If not, determine pumping frequency using above instructions.

1. Remove the four brass nuts from the bolts and fully remove the 22" lid to pump out. It is not necessary to remove adapter lid (on TZ-400, TZ-600, and TZ-1826 models) to pump out Trapzilla.
2. Begin by vacuuming out the grease from the top of the main chamber.
3. Upon reaching the horizontal baffle, you will see a hole to the rest of the grease and the solids. Be sure to lower the hose all the way to the bottom of the Trapzilla unit so that solids may be removed.
4. Have kitchen run water into unit to flush an remaining solids to the outlet end of the unit. If necessary, use a water hose with spray nozzle to rinse off inside of unit.
5. Secure lids in place and instruct kitchen to run water into unit until full

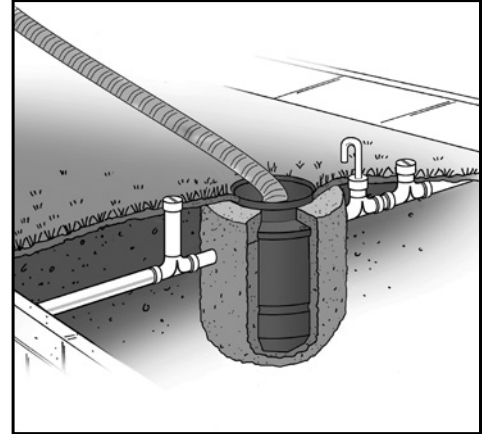

#### Notes:

DO NOT use mechanical crust breaking devices to break down any mat that has formed inside the Trapzilla unit.

DO NOT use grinding augers in maintenance of the Trapzilla unit.

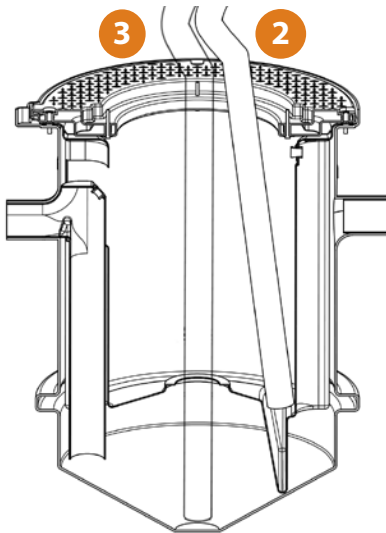

- 2** Begin by pumping grease from upper chamber, until you can see the entire horizontal baffle. May be necessary to use water hose to rinse out parts of upper chamber.

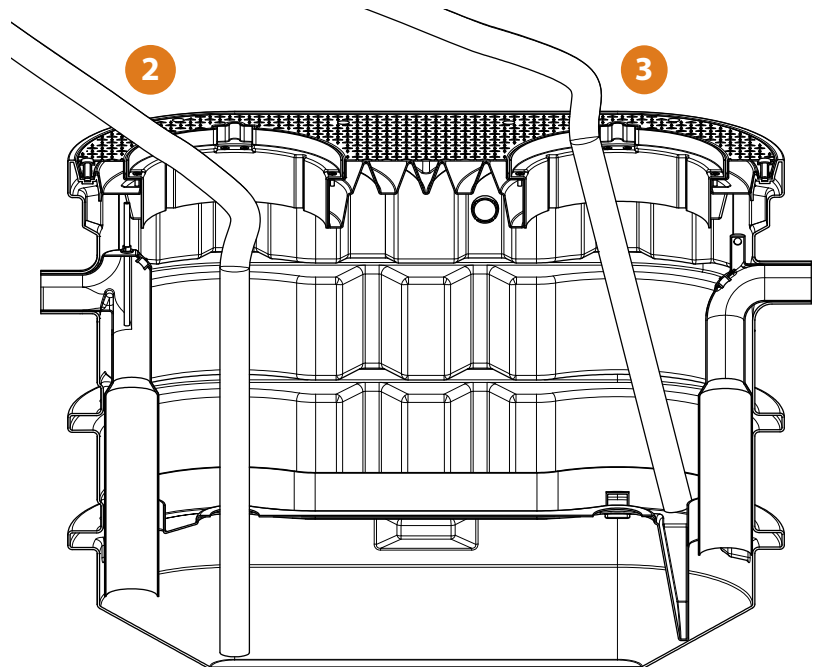

- 3** Drop hose into lower chamber through hole in horizontal baffle, pumping out all liquids and solids remaining. Again, it may be necessary to use water hose to rinse out lower chamber.