

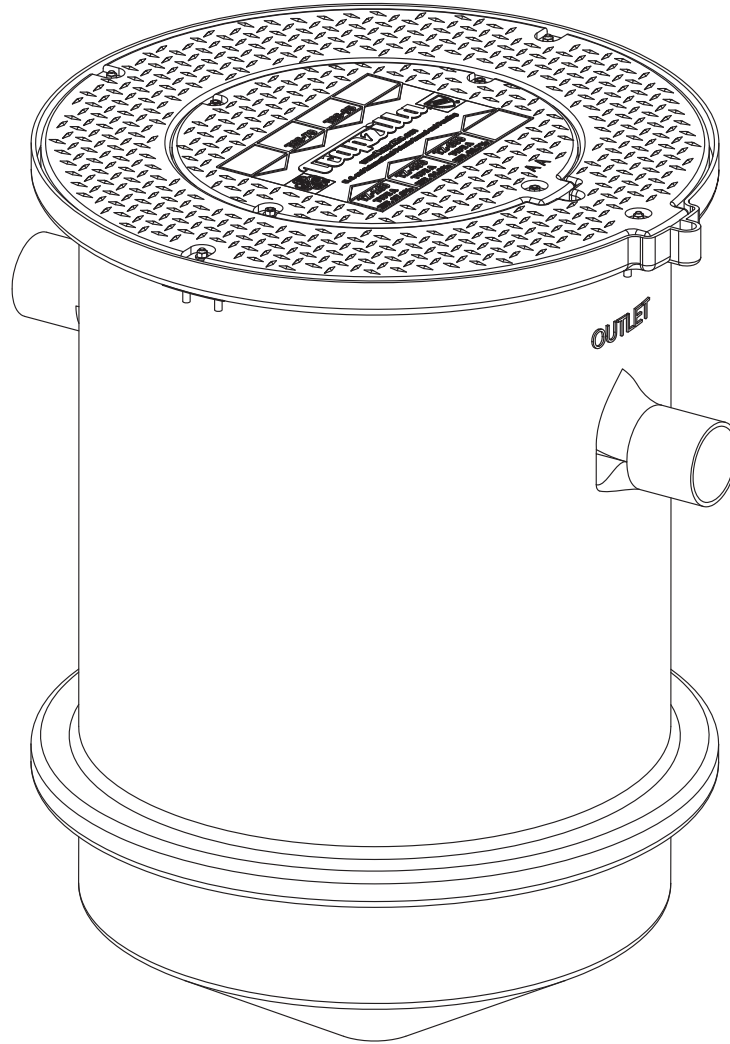

Installation & Maintenance Instructions For Trapzilla® Grease Interceptors



Conforms to ASME Standard
ASME A112.14.3-2000
Please consult Thermaco, Inc. for specific models tested,
certified and/or listed by these organizations.



**Please consult Thermaco, Inc. for specific models tested,
certified and/or listed by these organizations.*

Copyright ©2015 Trapzilla® Thermaco, Inc. • P.O.Box 2548 • Asheboro, NC 27204
Toll Free: (800) 633-4204 • Phone: (336) 629-4651 • Fax: (336) 626-5739
info@thermaco.com • www.trapzilla.com

Table of Contents

Section I: Trapzilla Grease Interceptors.....	3
System Overview.....	3
Section II: Models and Options.....	4
In-Ground Models.....	4
Above-Ground Models.....	5
Basic Models.....	6
Options.....	7
Section III: Trapzilla Installation.....	8
Plumbing Installation.....	8
Configurations.....	11
Above-Ground Installation.....	15
In-Ground Installation.....	17
Hanging Installation.....	22
Section IV: System Maintenance.....	23
Limited Warranty.....	25

System Overview

The **Thermaco, Inc. Trapzilla®** Supercapacity Grease Trap collects free-floating grease & oils contained in kitchen drain water flows. As most food service facility managers already know, grease buildup inside a building's grease containment system is a major cause of problems due to exterior drain line blockages. These problems jeopardize normal operations as well as create health and safety hazards within the facility itself.

The proper installation of a Trapzilla® Supercapacity Grease Trap can reduce or eliminate grease problems and costly sewer surcharges and fines through efficient separation and retention of free-floating grease & oils.

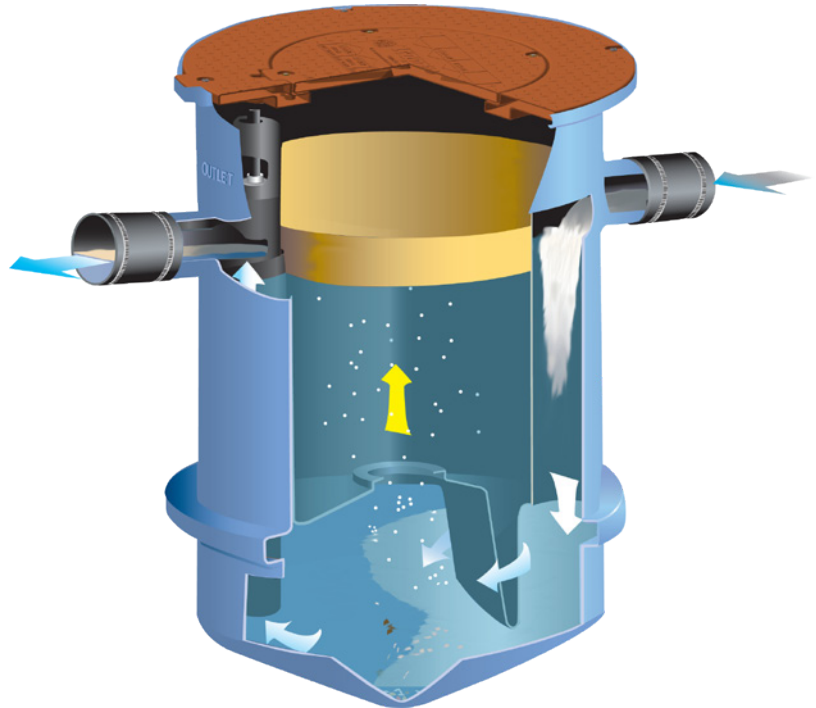

The Trapzilla offers patented flat separation curve technology. This means that the unit does not lose grease separation efficiency as it fills with retained grease. Thus, the Trapzilla stores large quantities of grease without losing efficiency. The unique compact design of the Trapzilla allows for installation into most facilities. Options are available that enable a Trapzilla unit to be installed on the floor, suspended from the ceiling or in-ground outside the facility.

Trapzilla units are designed to treat high flows of kitchen drainwater with large grease storage capacity within a small footprint unit. These units are easy to maneuver into position and just as easy to plumb.

Grease interceptors, grease traps, automatic recovery units, grease removal devices and other similar plumbing devices receiving kitchen flows from sinks, floor drains, woks and other food bearing sources may generate odors. There are many factors influencing odor evolution and dissemination. These include room ventilation, kitchen menu, ambient temperatures, ware washing practices, grease/oil input, daily input fluid volume, sanitizers, installation plumbing design and product maintenance/upkeep. Odors are usually prevented by good area ventilation, frequent fluid inputs, good product maintenance practices and proper product installation. Additional steps, including aeration, chlorination, pH control, improved area ventilation and additional maintenance may be needed at some sites.

In-Ground Models

TZ-600-ECA

635 pounds of grease storage, ASME rated at 75 gpm, while hydromechanically capable of flow rates of up to 150 gpm. Equipped with 4" inlet/outlet, 2" vessel vent connection, and 4" Low-Head Flow Control Accessory to limit flow to 75 gpm.

Comes with: 18" tall Extension Collar Adapter Lid Assembly with 22" diameter lid.

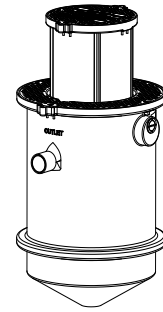

TZ-400-ECA

405 pounds of grease storage, ASME rated at 75 gpm. Equipped with 4" inlet/outlet, 2" vessel vent connection, and 4" Low-Head Flow Control Accessory to limit flow to 75 gpm.

Comes with: 18" tall Extension Collar Adapter Lid Assembly with 22" diameter lid.

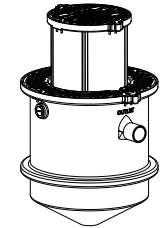

TZ-160-ECA

167 pounds of grease storage, ASME rated at 35 gpm. Equipped with 3" inlet/outlet, 2" vessel vent connection, and 3" Low-Head Flow Control Accessory to limit flow to 35 gpm.

Comes with: 22" diameter lid and 29" Telescoping Extension Collar.

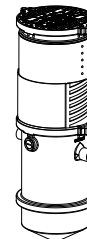

Above-Ground Models

TZ-600-SSA

635 pounds of grease storage, ASME rated at 75 gpm, while hydromechanically capable of flow rates of up to 150 gpm. Equipped with 4" inlet/outlet, 2" vessel vent connection, and 4" Low-Head Flow Control Accessory to limit flow to 75 gpm.

Comes with: Standard Adapter Top Cover with 22" diameter lid, and Support Stand SSOP-400/600.

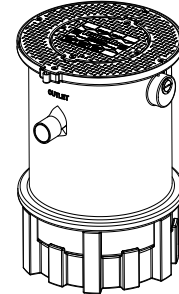

TZ-400-SSA

405 pounds of grease storage, ASME rated at 75 gpm. Equipped with 4" inlet/outlet, 2" vessel vent connection, and 4" Low-Head Flow Control Accessory to limit flow to 75 gpm.

Comes with: Standard Adapter Lid Ring with 22" diameter lid, and Support Stand SSOP-400/600.

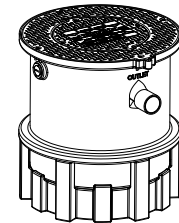

TZ-160-SSA

167 pounds of grease storage, ASME rated at 35 gpm. Equipped with 3" inlet/outlet, 2" vessel vent connection, and 3" Low-Head Flow Control Accessory to limit flow to 35 gpm.

Comes with: 22" diameter lid and Support Stand SSA-160.

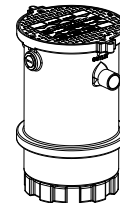

Basic Models

TZ-600

635 pounds of grease storage, ASME rated at 75 gpm, while hydromechanically capable of flow rates of up to 150 gpm. Equipped with 4" inlet/outlet, 2" vessel vent connection, and 4" Low-Head Flow Control Accessory to limit flow to 75 gpm.

Comes with: Standard Adapter Lid Ring with 22" diameter lid.

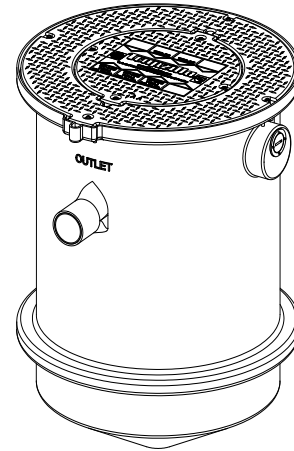

TZ-400

405 pounds of grease storage, ASME rated at 75 gpm. Equipped with 4" inlet/outlet, 2" vessel vent connection, and 4" Low-Head Flow Control Accessory to limit flow to 75 gpm.

Comes with: Standard Adapter Lid Ring with 22" diameter lid.

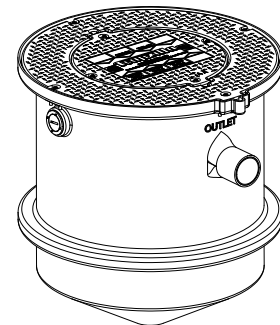

TZ-160

167 pounds of grease storage, ASME rated at 35 gpm. Equipped with 3" inlet/outlet, 2" vessel vent connection, and 3" Low-Head Flow Control Accessory to limit flow to 35 gpm.

Comes with: 22" diameter lid.

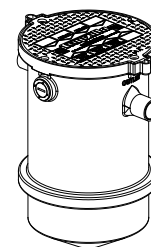

Options

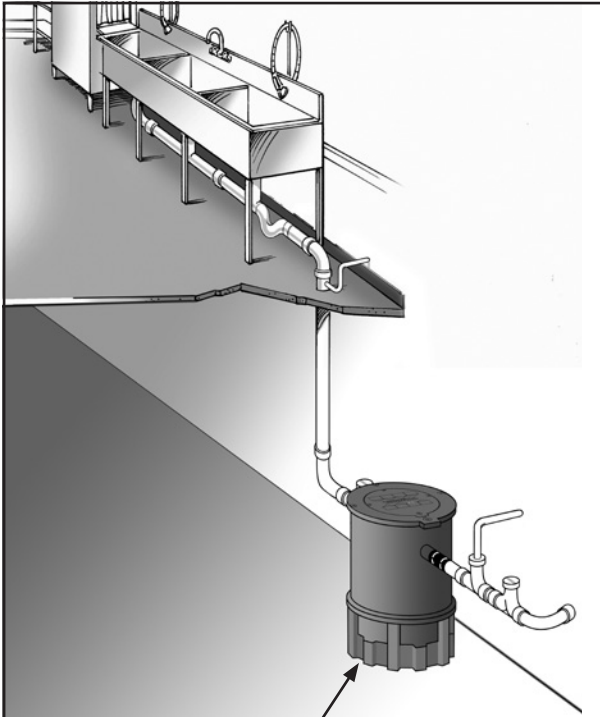

SSOP-400/600

Support Stand for TZ-400 and TZ-600 models
 Allows unit to be installed directly on the floor in a basement or mechanical room.
 *Included with -SSA Models

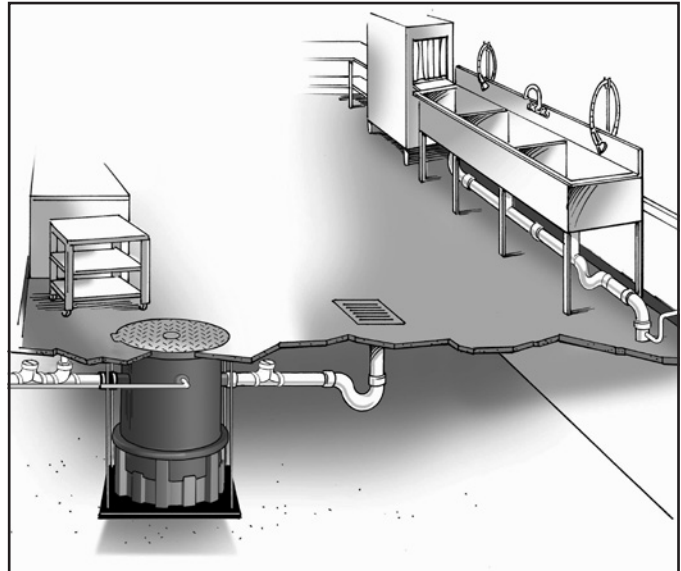

FTCA-36

Fabricated Top Cover Assembly with 36" diameter for additional traction in high foot-traffic areas and 4" Brass cleanout port.

FTCA-22 (not shown)

22" diameter cover available for In-Ground installations.

ECA-TZ-29 (in blue) for Trapzilla Models

These field-modifiable extension collars available to provide additional depth for existing kitchen drainage piping.

-ECA Models ship with built-in 0-18" extension collar.
ECA-TZ-29 adds 0-29" depth to -ECA Models or 4-29" to Basic Models.

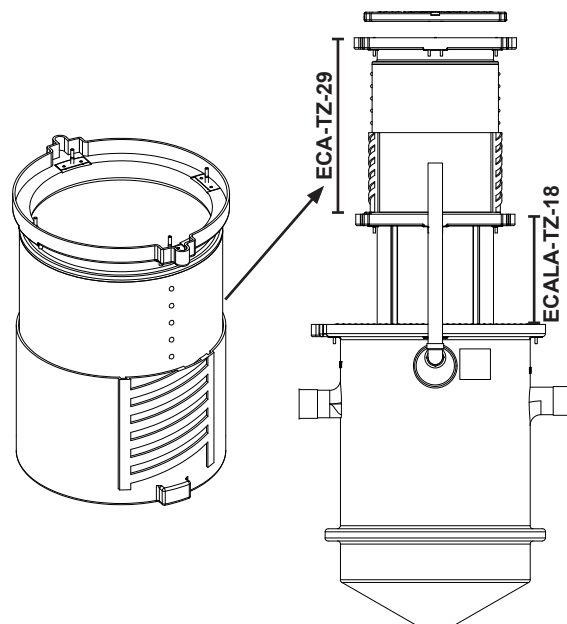



Plumbing Installation

Locating the Unit

The system should be visible and easily accessible for maintenance and inspection. Options are available to install the Trapzilla in a basement, suspended from a ceiling or in-ground in an exterior location. Make sure adequate room is provided around the unit to allow easy access for a pump truck operator. Make sure the height above the Trapzilla access cover is enough to properly service the system.

Inlet/Outlet Piping

The inlet and outlet piping connections require flexible sleeve pipe couplings. Keep outlet piping as straight as possible. Thermaco, Inc. recommends installation of Two-Way Cleanouts on both the Inlet and Outlet of Trapzilla Interceptors and Solids Separators in accordance with all applicable laws, regulations and codes. **These cleanouts should match the size of the Inlet and Outlet Piping (i.e. for 4" plumbing, a 4" cleanout should be used).** Use only "sweep" connections. Do not reduce the pipe sizing on the outlet piping. Do not install "P" trap on outlet connection of system. (Note: The system already has a internal gas trap)

Flow Controls

Trapzilla systems are supplied with a Low-Head Flow Control module (LHFC). This should be connected to the inlet of the Trapzilla unit in situations where flow rate needs to be restricted to the ASME rated flow or when vented flow control is required by local code.

Venting the Outlet

An outlet vent or approved air admittance valve of at least 1/2 the diameter of the system's outlet connection must be present as close as possible to the Trapzilla outlet to prevent possible siphonage problems. The Vent on the Outlet piping is to be installed in accordance with all applicable laws, regulations and codes. Failure to provide a vent for the system voids Thermaco's Limited Warranty for the system.

For High Head Height Applications Over Six (6) Feet (1.95 m)

For installations where there is head height of greater than 6 feet (1.95 meters), Thermaco, Inc. recommends installation of a code-approved Vented Flow Control Assembly (Thermaco VFCA not included with Trapzilla).

Note: Drawings for reference only. Equipment must be installed in compliance with all applicable laws, regulations and codes, including plumbing codes. Installation should be performed by a qualified plumber.

Plumbing Installation

Venting of the Trapzilla tank is recommended by the manufacturer and required for in-door installations.

- Vent the tank through the provided 2" NPT threaded connector on the side of the tank (This vent may be located above the outlet or on the side of the tank depending on model).
- Remove and discard the 2" plug and connect 2" vent lines as indicated below.

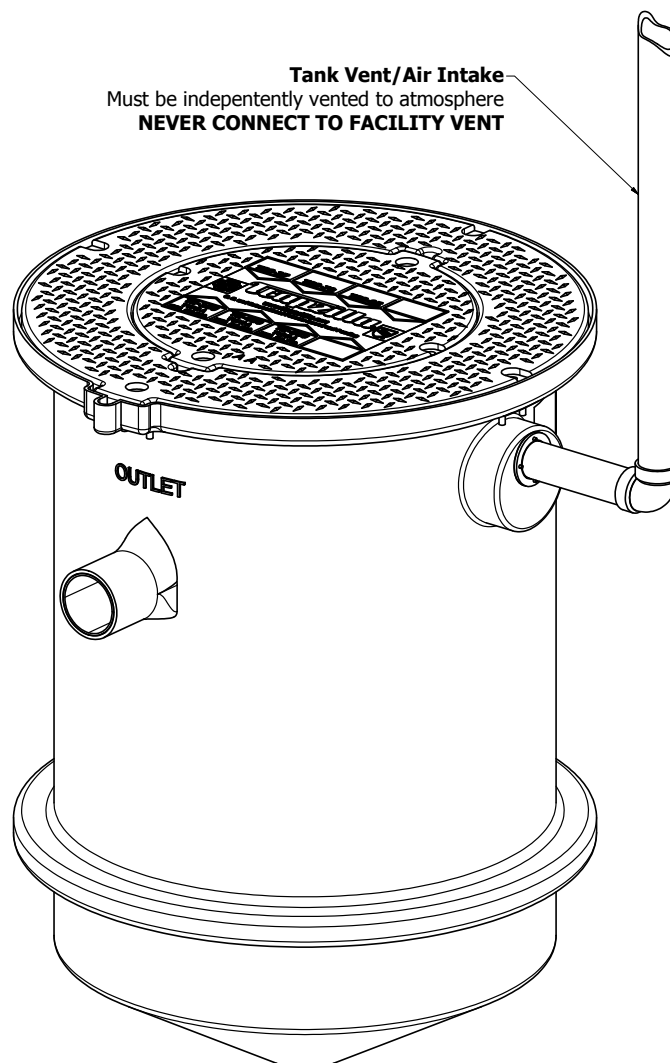

Note: Drawing for reference only. Equipment must be installed in compliance with all applicable laws, regulations and codes, including plumbing codes. Installation should be performed by a qualified plumber.

Plumbing Installation

Plumbing Installation (for one Trapzilla GI)

Each Trapzilla unit is shipped with a Low Head Flow Control module (see LHFC box for additional instructions). This needs to be installed to the inlet of the Trapzilla and connected to a code-approved air intake. Thermaco, Inc. recommends installation of Two-Way Cleanouts on both the Inlet and Outlet of Trapzilla® in accordance with all applicable laws, regulations and codes. **These cleanouts should match the size of the Inlet and Outlet Piping (i.e. for 4" plumbing, a 4" cleanout should be used).** A Vent on the Outlet piping is also to be installed in accordance with all applicable laws, regulations and codes.

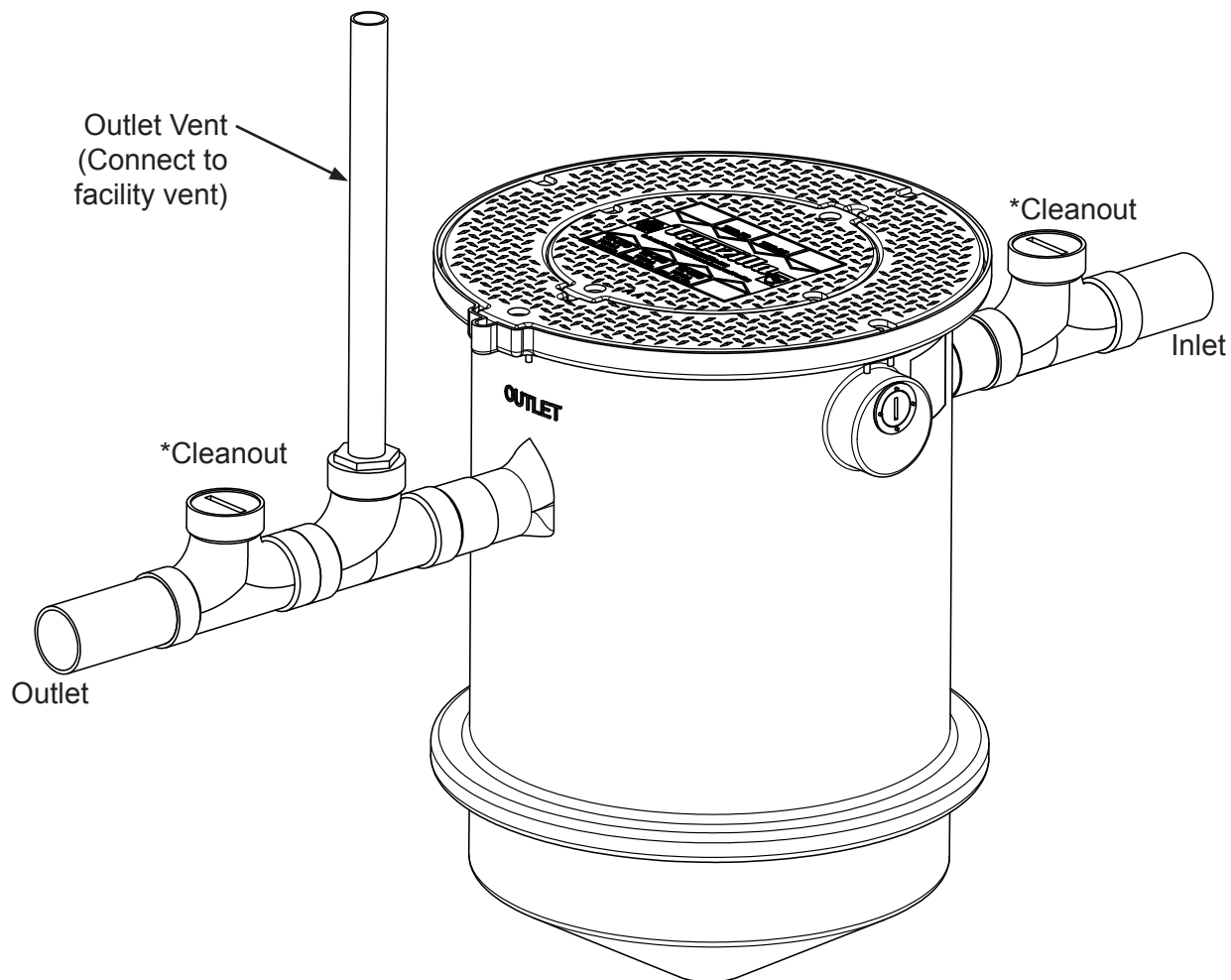

*Use a Two-Way Cleanout before and after all Trapzilla Installations

Note: Drawing for reference only. Equipment must be installed in compliance with all applicable laws, regulations and codes, including plumbing codes. Installation should be performed by a qualified plumber.

Configurations

Two Trapzilla Units

Two Trapzilla Grease Interceptors should be installed in parallel with a Flow Splitter diverting the flow. Place Two-Way Cleanouts before, between and after the units as shown below, including before and after the flow splitter. Make sure to connect an outlet vent after each Trapzilla Grease Interceptor. A Low Head Flow Control (LHFC) is shipped with each unit, and if needed should only be installed after the first Cleanout and before the 4" Flow Splitter.

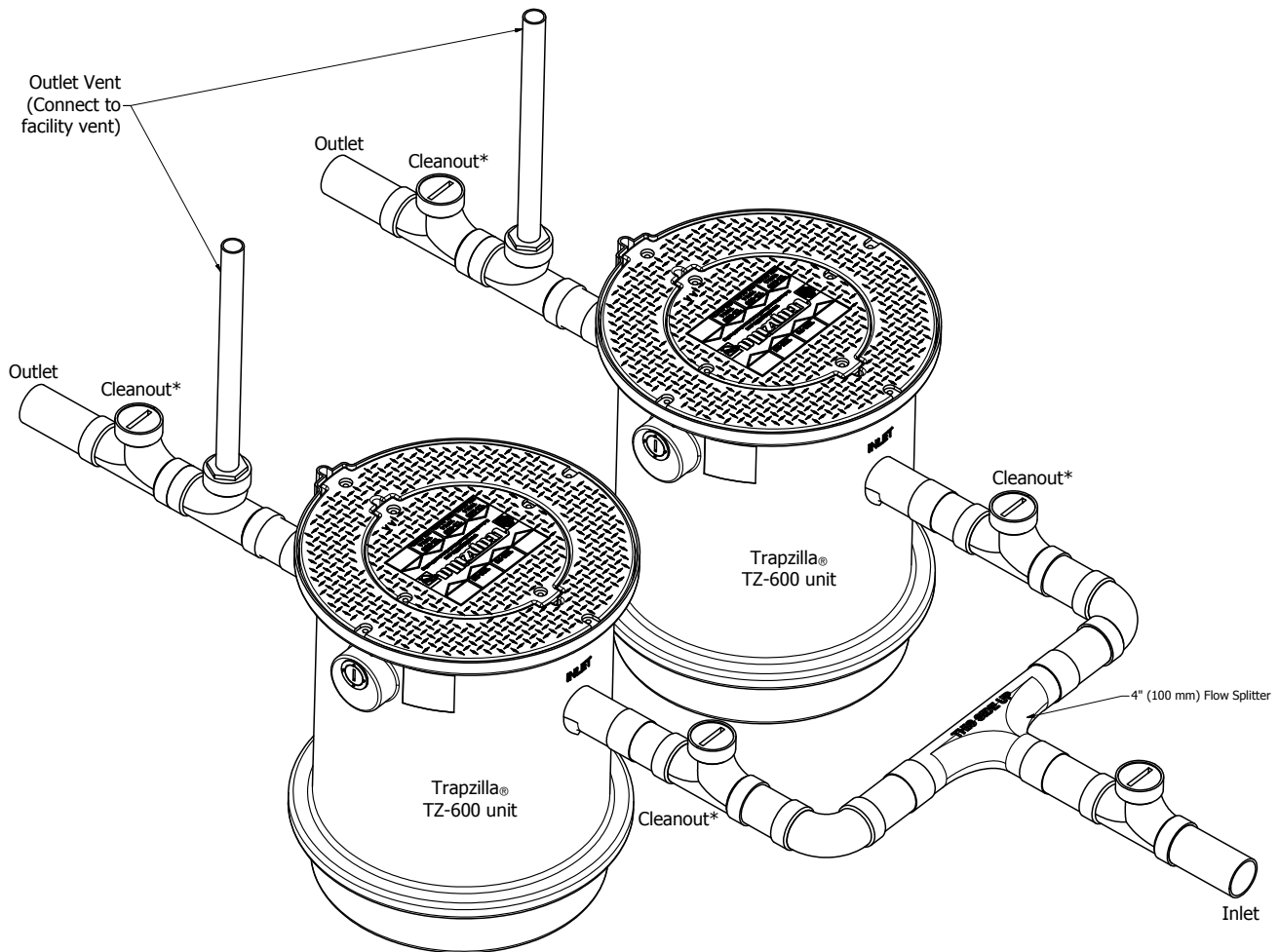

*Use a Two-Way Cleanout before and after all Trapzilla Installations

Note: Drawing for reference only. Equipment must be installed in compliance with all applicable laws, regulations and codes, including plumbing codes. Installation should be performed by a qualified plumber.

Configurations

Two Trapzilla GI's in Series or One Solids Separator and One Trapzilla

Alternatively, two Trapzilla Grease Interceptors may be installed in series. A single Trapzilla Solids Separator and Trapzilla Grease Interceptor should always be installed in series. Place Two-Way Cleanouts before, between and after the units as shown below. Make sure to connect an outlet vent after the Trapzilla Grease Interceptor. A Low Head Flow Control (LHFC) is shipped with each unit, and if needed should only be installed after the first Cleanout and before the Trapzilla Solids Separator.

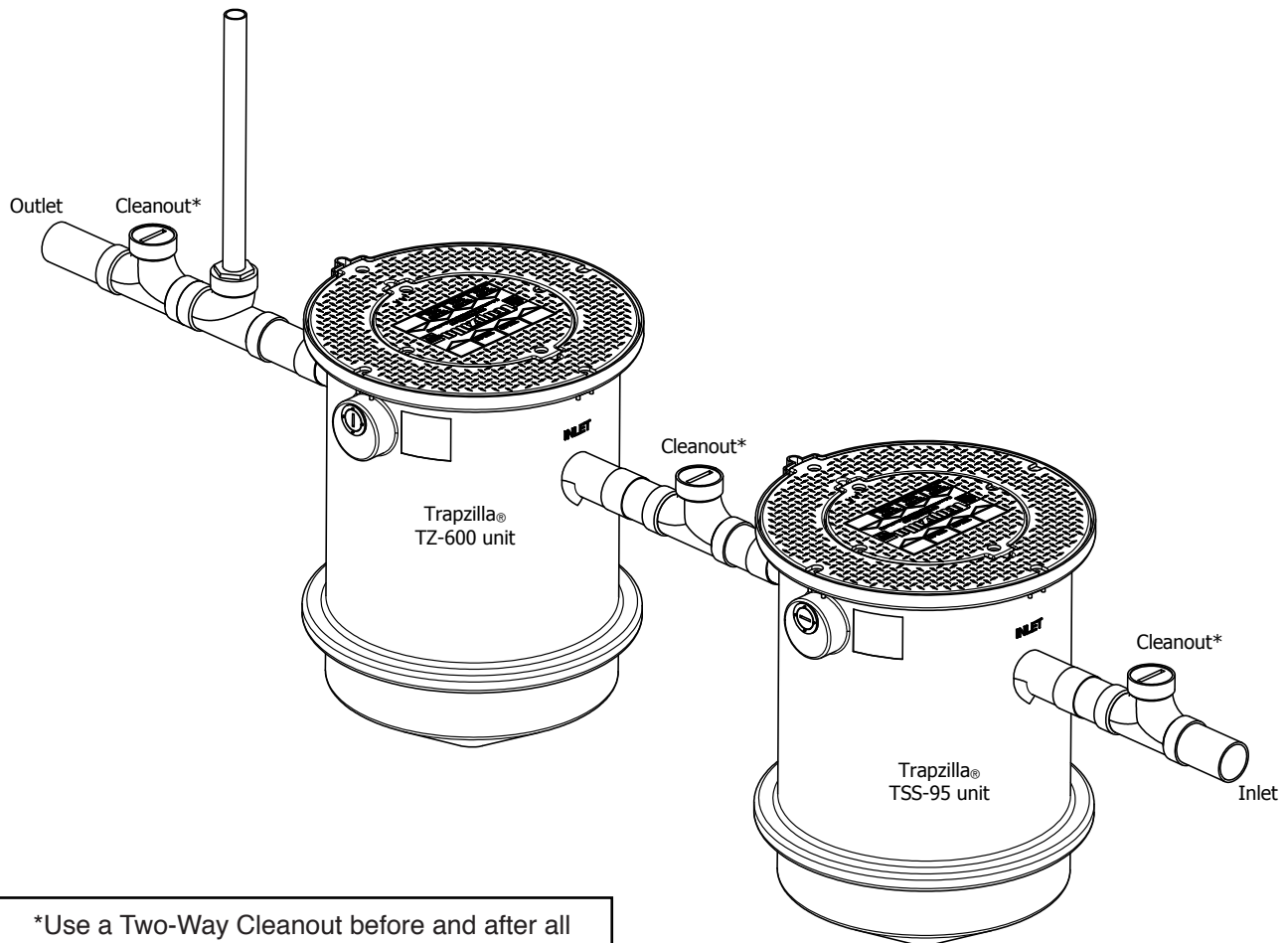

*Use a Two-Way Cleanout before and after all Trapzilla Installations

Note: Drawing for reference only. Equipment must be installed in compliance with all applicable laws, regulations and codes, including plumbing codes. Installation should be performed by a qualified plumber.

Configurations

One Solids Separator and Two Trapzilla Units

A single Trapzilla Solids Separator and two Trapzilla Grease Interceptors should be installed by placing the Solids Separator in line and then using a Flow Splitter to divert the water flow to two separate Trapzilla units in parallel. Place Two-Way Cleanouts before, between and after the units as shown below, including before and after the flow splitter. Make sure to connect an outlet vent after the Trapzilla Grease Interceptor. A Low Head Flow Control (LHFC) is shipped with each unit, and if needed should only be installed after the first Cleanout and before the Trapzilla Solids Separator.

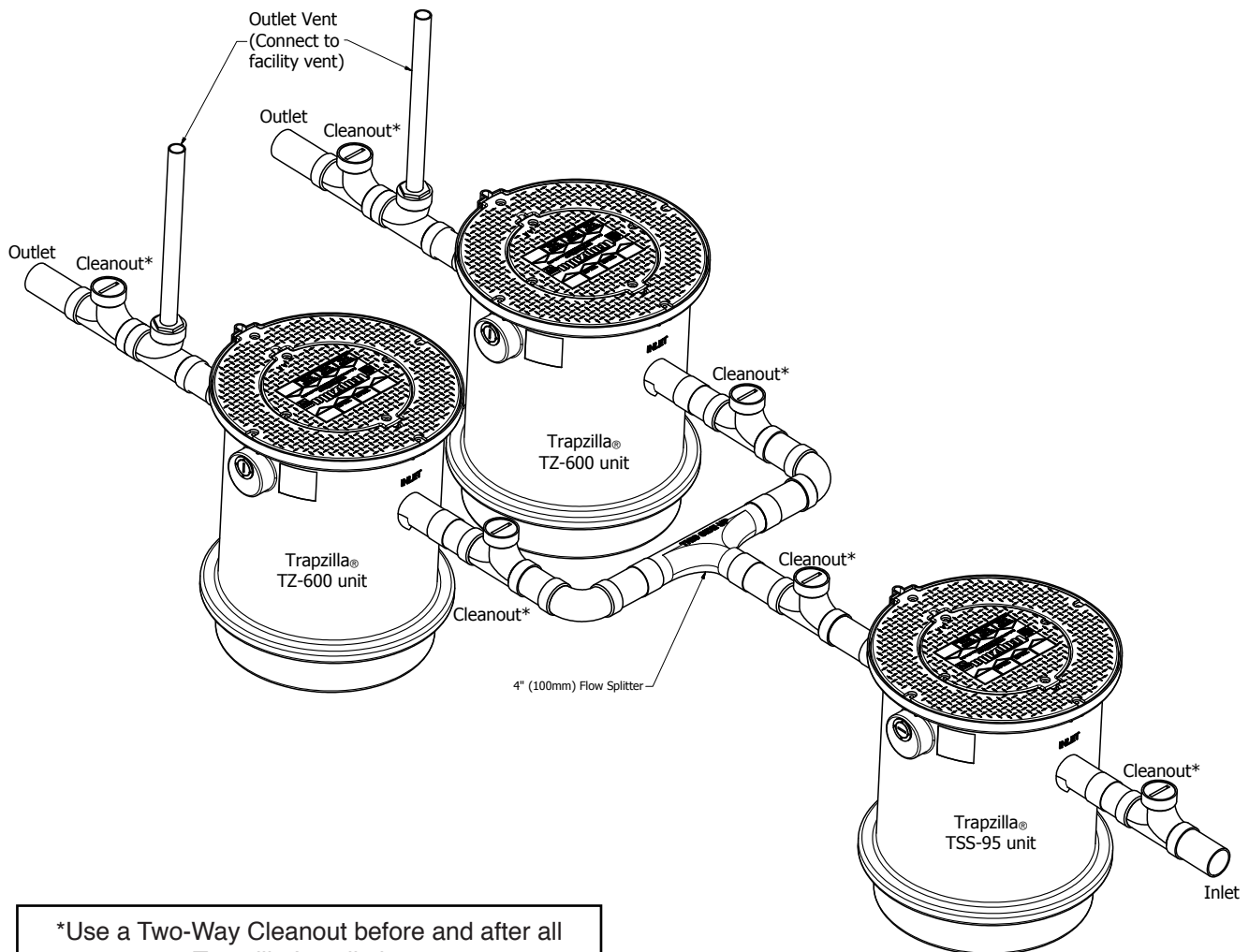

*Use a Two-Way Cleanout before and after all Trapzilla Installations

Note: Drawing for reference only. Equipment must be installed in compliance with all applicable laws, regulations and codes, including plumbing codes. Installation should be performed by a qualified plumber.

Configurations

Two Solids Separators and Two Trapzilla Units

Two Trapzilla Solids Separator and two Trapzilla Grease Interceptors should be installed by placing a Flow Splitter to divert the water flow to two separate Solids Separators and Trapzilla units in parallel. Place Two-Way Cleanouts before, between and after the units as shown below, including before and after the flow splitter. Make sure to connect an outlet vent after the Trapzilla Grease Interceptor. A Low Head Flow Control (LHFC) is shipped with each unit, and if needed should only be installed after the first Cleanout and before the 4" Flow Splitter.

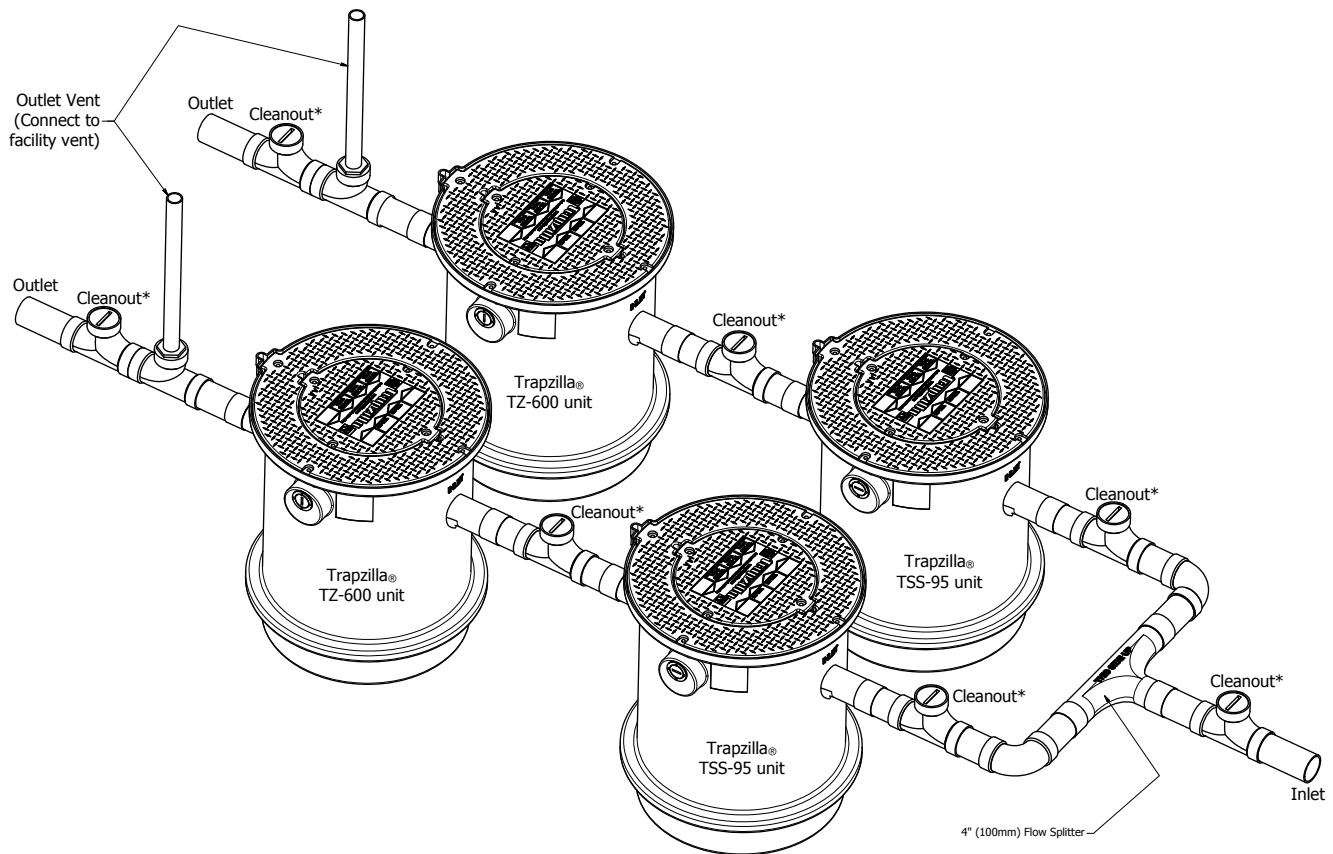

*Use a Two-Way Cleanout before and after all Trapzilla Installations

Note: Drawing for reference only. Equipment must be installed in compliance with all applicable laws, regulations and codes, including plumbing codes. Installation should be performed by a qualified plumber.

Above-Ground Installation

Using a model-specific Support Stand, a Trapzilla unit may be installed directly on top of the floor in a location such as a basement or mechanical room.

TZ 400 or TZ-600: SSOP-400/600

TZ-160: SSA-160

***These items ship with all -SSA models.**

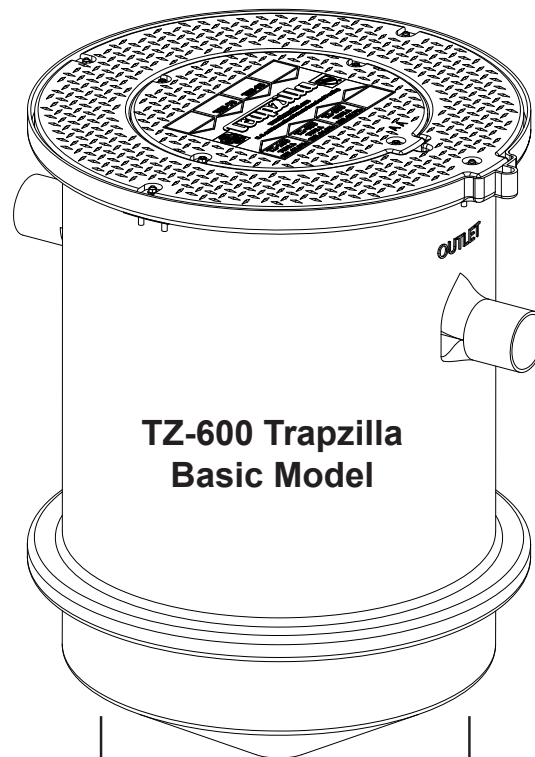

**TZ-600 Trapzilla
Basic Model**

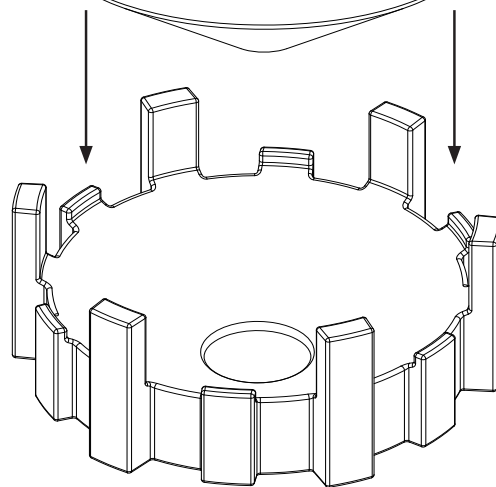

SSOP-400/600 Support Stand

NOTE: SUPPORT STAND MUST BE INSTALLED OVER A CONTINUOUS SURFACE. NON-CONTINUOUS SURFACES SUCH AS GRATES ARE NOT SUITABLE FOR SUPPORT.

The SSOP Support Stand is a one-piece assembly with a conical center that sits on the floor. It does not add appreciable height to the assembly.

Above-Ground Installation

When installing multiple Trapzilla units in series, the change in elevation from the inlet to the outlet of a unit requires that each preceding unit be installed 1" higher than the unit after it. For above-ground units, pressure treated plywood may be placed fully beneath the support stand to create the height difference.

All installations inside of a building must have a vessel vent installed and piped to atmosphere.

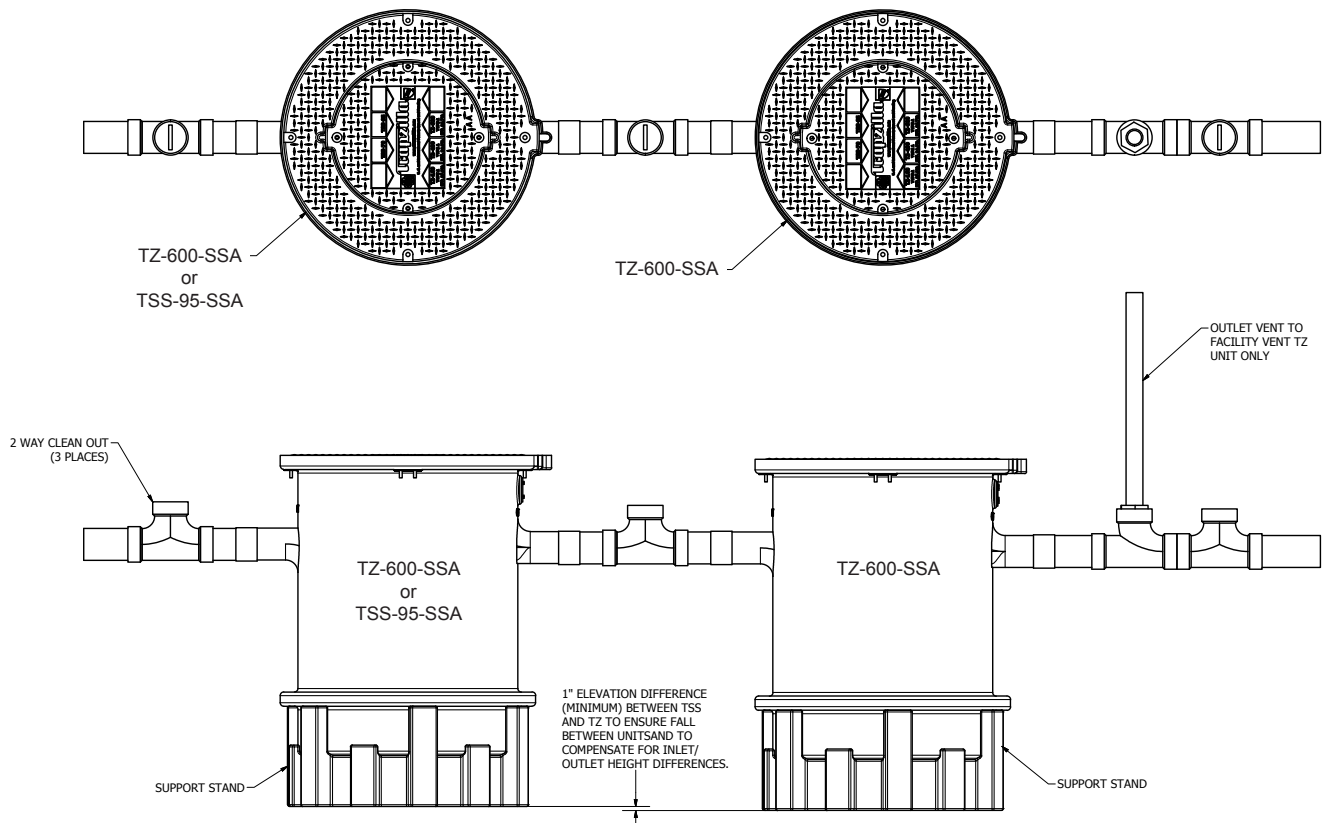

In-Ground Installation

A Trapzilla unit may also be installed in the ground outside of the facility. For instances where the facility drainage piping requires an extension collar that is no more than 18", use the instructions for the full TZ-600-ECA unit. If the unit is to be deeper in the ground, the ECA-TZ-29 Extension Collar Assembly may be installed to align the Trapzilla inlet with the drainage piping. The ECA-TZ-29 may be trimmed in the field to fit. Trim both the inner and outer portions of the extension collar to make shorter than collapsed height. Thermaco, Inc. strongly recommends surrounding the in-ground Trapzilla with concrete to provide additional structural strength and to offset buoyancy effects. For Buoyancy Calculations & suggested concrete fill quantities please see page 21. Use the full TZ-600-ECA for 0-18" of collar needed or purchase separately the TZ-600 and ECA-TZ-29 for 4-29" of collar needed.

In-Ground Installations inside of a building must have a vessel vent installed and piped to atmosphere.

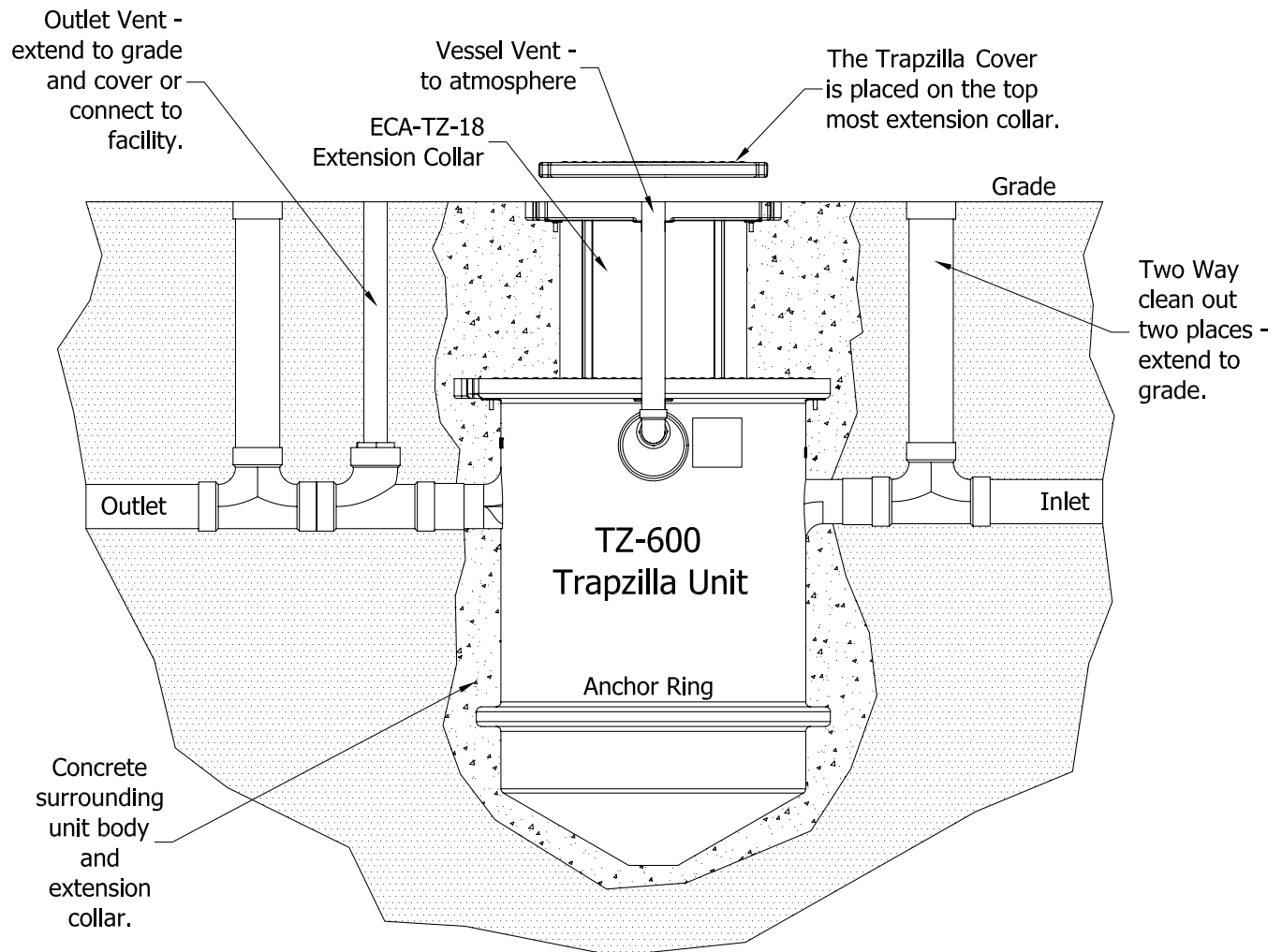

* Units using additional extension collars must use adapter lid and/or extension collars included with unit.

In-Ground Installation

When installing multiple Trapzilla units in series, the change in elevation from the inlet to the outlet of a unit requires each preceding unit to be installed 1" higher than the unit after it.

In-Ground Installations inside of a building must have a vessel vent installed and piped to atmosphere.

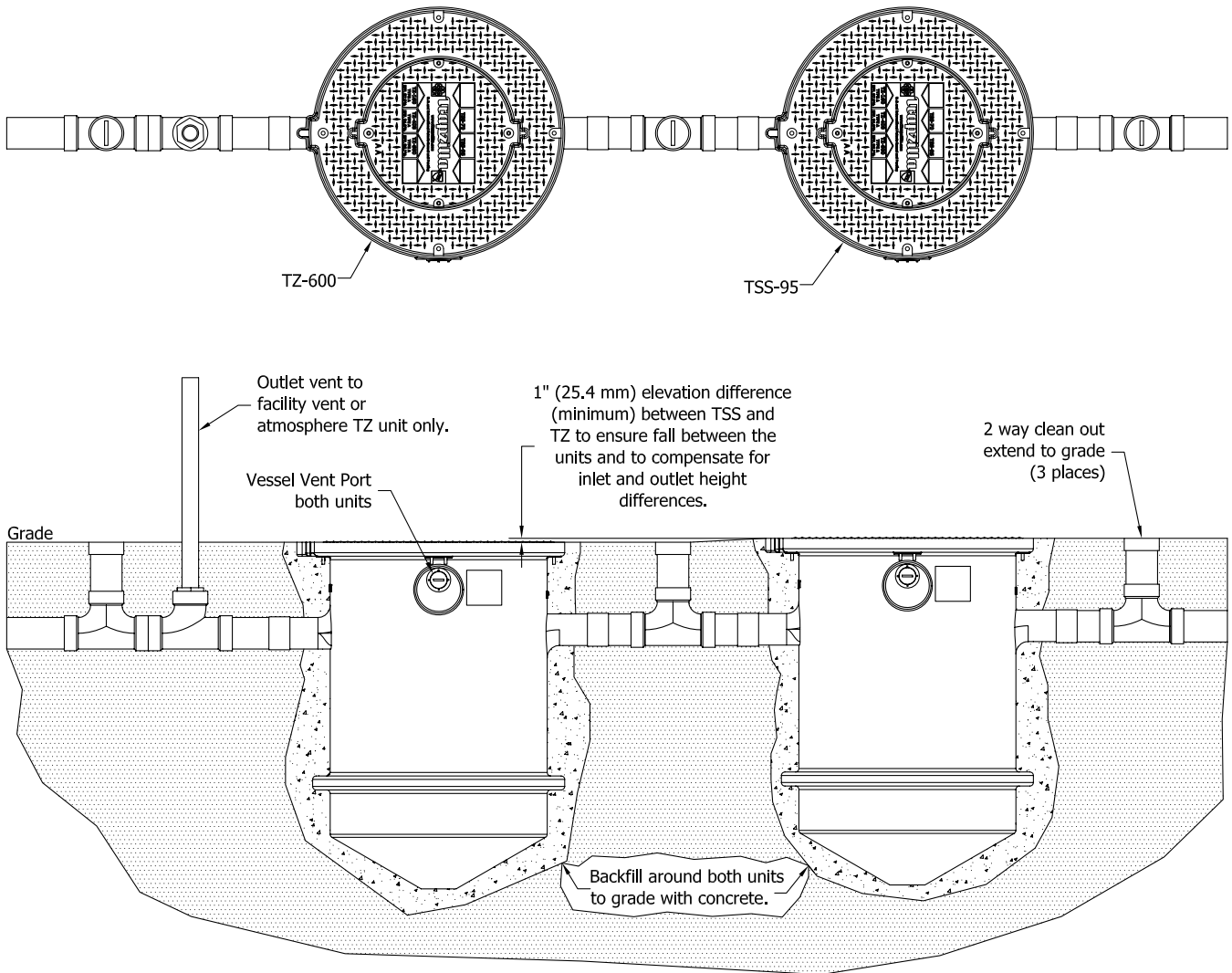

* Units using additional extension collars must use adapter lid and/or extension collars included with unit.

In-Ground Installation

Trimming and Setting the ECA-TZ-18 Single-Piece Extension Collar

In-Ground Trapzilla Models ship with a built-in, single-piece, 18" extension collar that must be trimmed and then set to the correct height to bring the Solid Top Cover to grade.

Follow the steps below to set the extension collar prior to backfilling the hole with concrete.

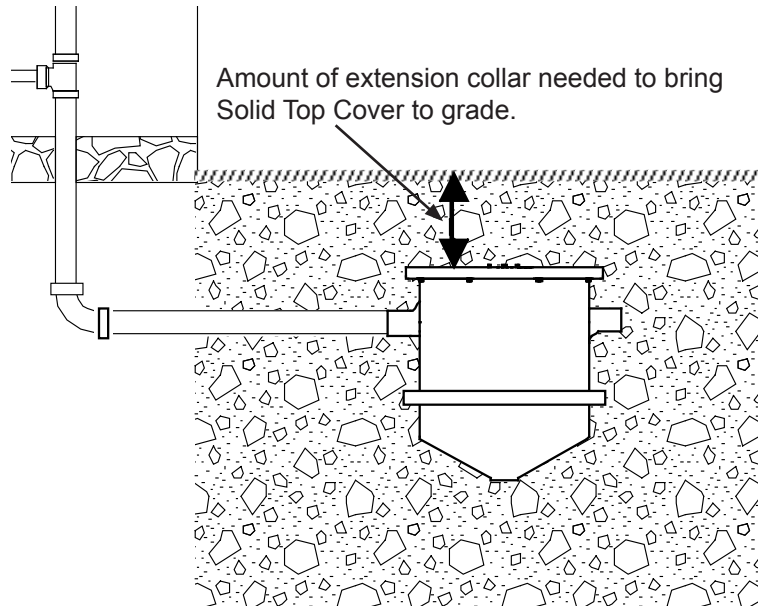

Step 1: With the Trapzilla unit installed in its permanent location, raise the telescoping extension collar to finished grade or floor level. Measure the height from the top of the unit to this finished extension collar height and record this dimension.

Note: If the floor will have a tile covering allow for the tile thickness when determining the extension collar height.

Step 2: Remove the extension collar adapter ring from the unit with the extension collar still in place. On the underside of the cover, mark the excess extension collar length at the bottom of the four (4) "skirt" portions of the adapter ring. Check the extension collar height dimension frequently during this marking to ensure that the collar has not moved. Extend this mark between the gaps in the "skirt" so that the collar is marked all around.

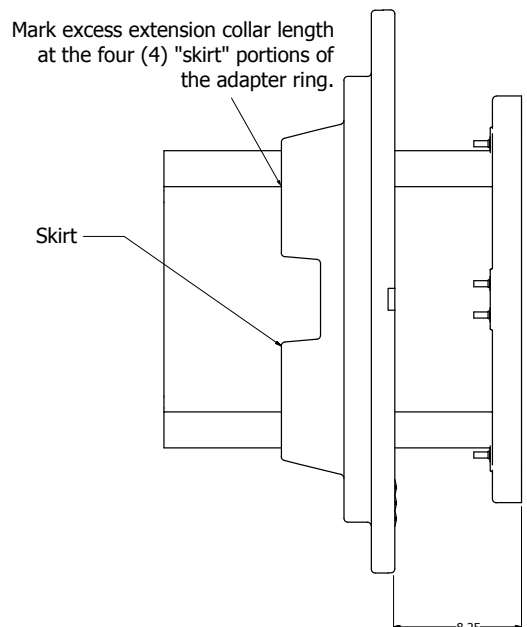
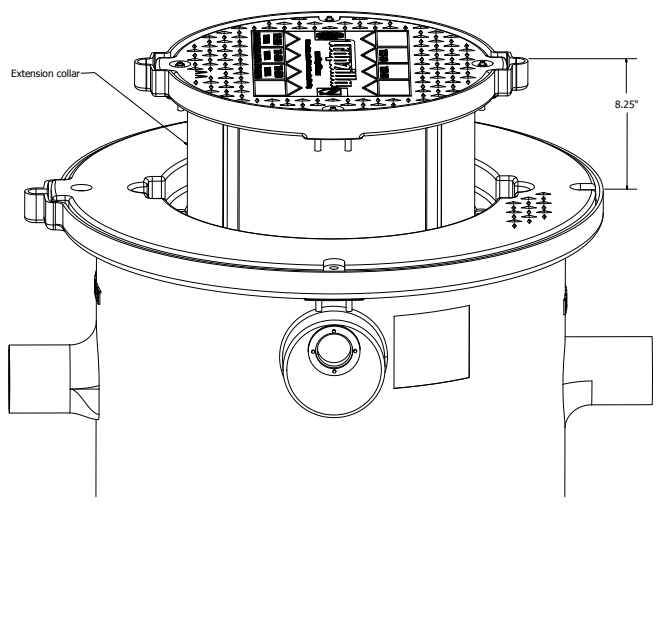

In-Ground Installation

Step 3: Remove the extension collar from the adapter ring and, with an appropriate saw, cut along the line created in Step 2 to remove the excessive extension collar.

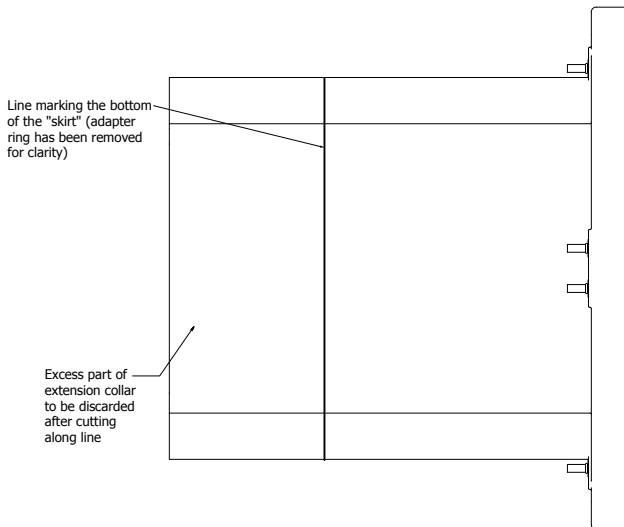

Step 4: Reinsert the extension collar into the adapter ring ensuring that the cover alignment key on the extension collar is aligned with its recess in the adapter ring. Reset the extension collar height to the dimension determined in Step 1.

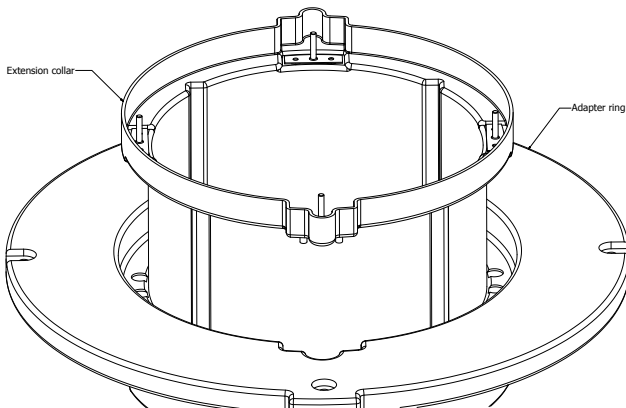

Step 5: Working from the bottom of the assembly, install eight (8) self-drilling, self-tapping screws (provided) through the extension collar wall and into the adapter ring. Two of these screws should be installed in each of the four (4) skirt areas of the adapter ring. Check the extension collar height dimension frequently during this operation to ensure that the collar has not moved. **Note:** Use caution when tightening these screws to ensure that they do not strip.

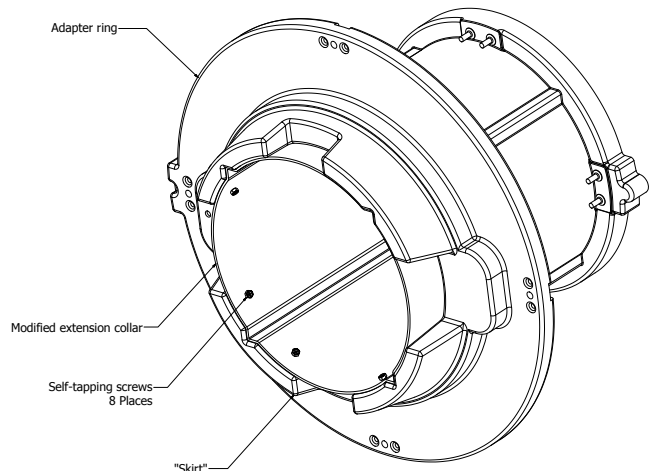

Step 6: Place the adapter ring/extension collar assembly onto the Trapzilla unit. Position the small cover onto the extension collar. Secure the adapter ring and the small cover with the brass nuts and flat washers provided. Seal the gap between the 18" extension collar and extension collar adapter ring using a silicone sealant.

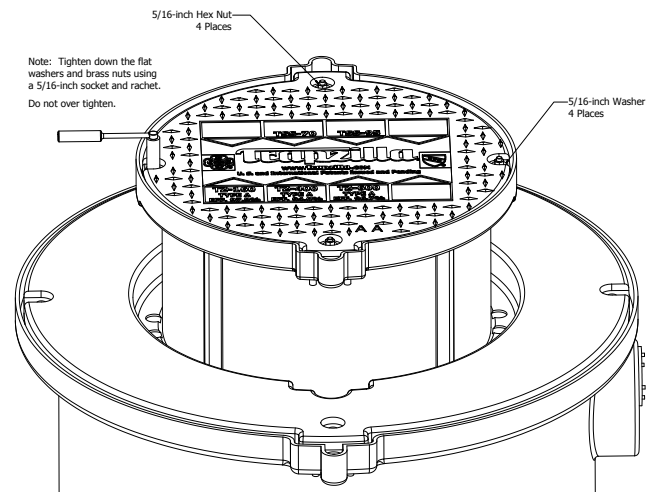

In-Ground Installation

In order to offset the effects of buoyancy caused by groundwater (high water tables), strengthen the sideload of the unit, and prevent movement of the unit in the event of shifting earth, Thermaco, Inc. recommends concrete be poured around the entirety of Trapzilla® units installed in-ground in the amounts of concrete specified in the table below. The concrete must be poured continuously and completely surrounding the Trapzilla® body (and Extension Collars if applicable) to ensure proper strength and security at a compression strength of 4000 psi (C28/35).

Concrete Calculations for TZ Models/Components*

Trapzilla Model	Amount of Concrete	
	Weight in lbs. (Kg)	Volume in Cubic Yards (m ³)
TZ-600-ECA	1975	0.50
TZ-400-ECA	1525	0.40
TZ-160-ECA	550	0.15
ECA-TZ-29*	600	0.20

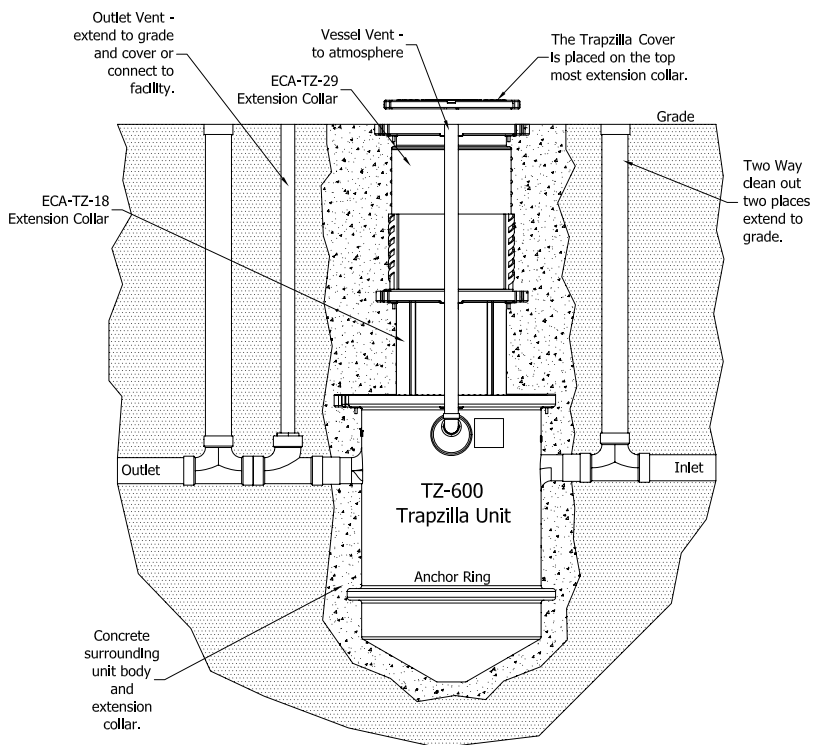

Pictured Left:

Installation of TZ-600-ECA unit with Built-In 18" Extension Collar fully extended and 29" Two-Piece Extension Collar fully extended for a total of 47" of additional depth for unit. Concrete should fully encircle the unit up to the surface. A small amount of space (up to 4") may be left unfilled to cover with dirt and grass if installed outside.

*** In-ground installation instructions only applicable for units installed where center of outlet pipe is no more than 60" below grade. For all installations deeper than this, Thermaco must be contacted to verify site conditions and provide further instructions for proper installation. Failure to abide by this instruction will result in voiding the warranty of the unit.**

Hanging Installation

Using the Hanging Assembly option, a Trapzilla unit may be suspended from a ceiling below the floor of a kitchen or other room.

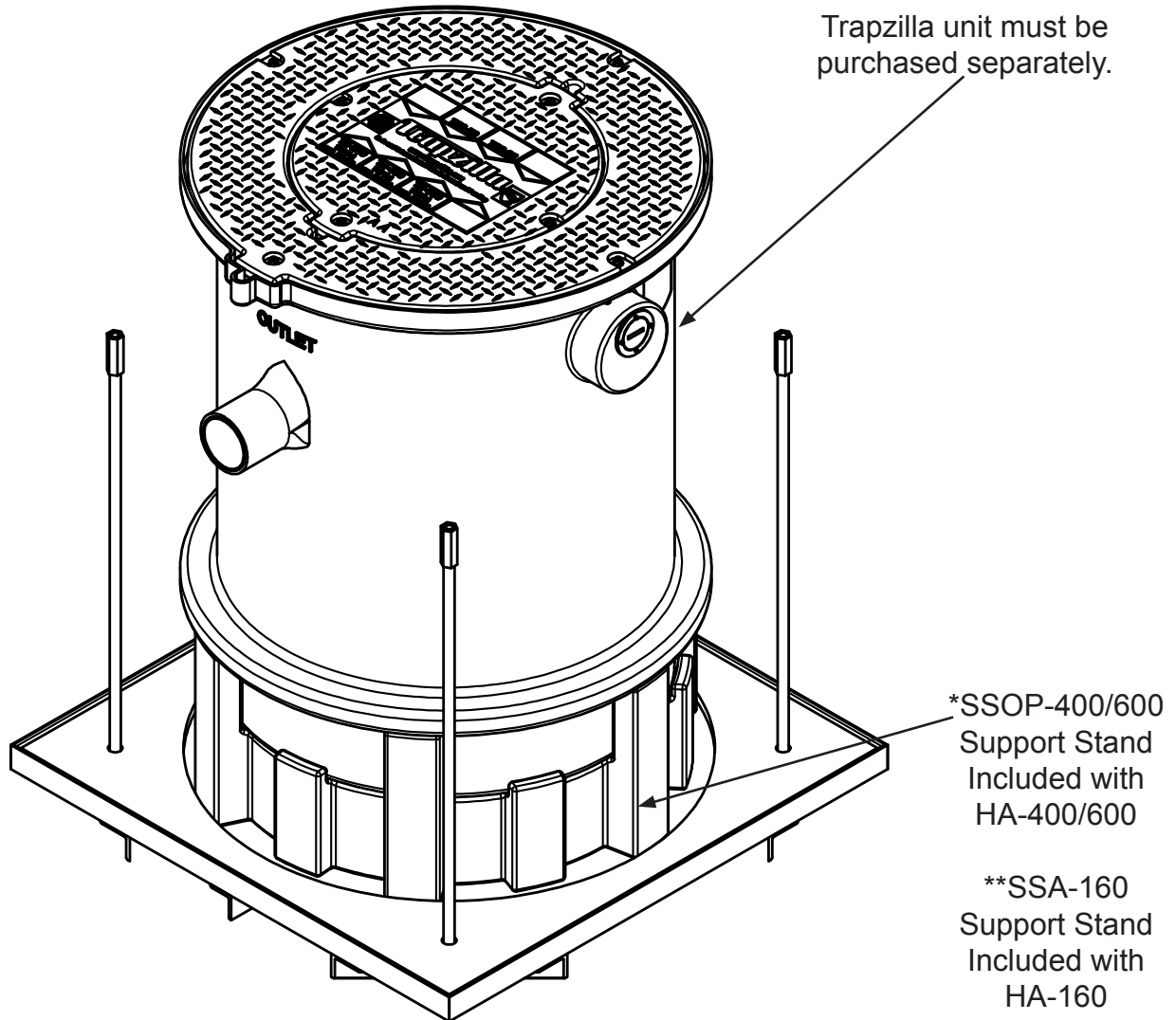

Thermaco, Inc. supplies the frame and support stand with the hanging assembly. This kit needs to be installed by a licensed contractor. The contractor is responsible for determining weight loads, preparation of the floor for installation and any construction necessary for installation of the suspension kit.

Note: Drawing for reference only. Equipment must be installed in compliance with all applicable laws, regulations and codes, including plumbing & building codes. Installation should be performed by a qualified plumber and contractor.

Measuring Grease/Solids Levels

Due to its unique design, Trapzilla is capable of retaining high quantities of grease in a compact footprint. Therefore, unlike traditional interceptors, Trapzilla can hold an extraordinarily high percentage of its volume in grease without losing separation efficiency. To determine the current levels of grease/solids in your Trapzilla grease interceptor, follow the instructions below.

1. Remove four nuts/washers securing the Solid Top Cover. Note the size of the unit which is marked on the cover by a metal plate.
2. Place a grease/sludge dipstick into the center of the Trapzilla, making sure that it goes through the hole in the horizontal baffle.
3. Once the dipstick has found its natural resting place at the lowest point in the conical shaped bottom, take the measurement.
4. Remove dipstick and compare grease/sludge levels to the corresponding unit in the charts below.

	Grease		Solids	
	Total Capacity (depth):	Ready to pump at (depth):	Total Capacity (height):	Ready to pump at (height):
TZ-600	17"	13.75"	14"	12"
TZ-400	9.375"	7.5"	14"	12"
TZ-160	13"	10.5"	10"	8"

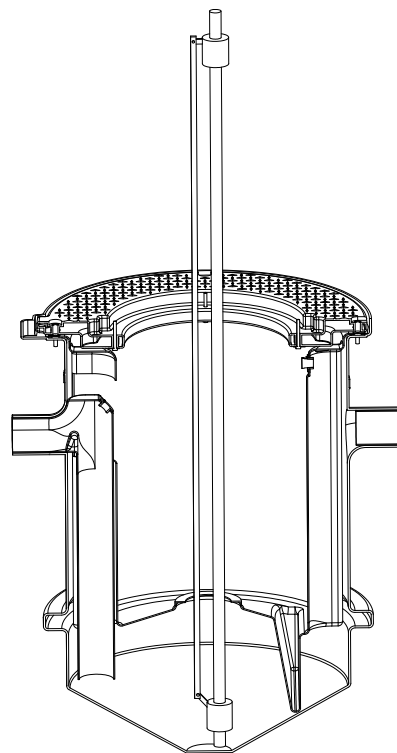

Take grease measurement from top of liquid level downward and compare to chart above.

Take solids/sludge measurement from bottom of unit upward and compare to chart above.

Maintaining Trapzilla

Periodically, the Trapzilla® unit will need to be serviced which involves pumping out the accumulated grease & solids. Each lid has four brass nuts securing the lid. Fully remove the lid to access the grease. Begin by taking the grease from the top of the main chamber. Upon reaching the horizontal baffle, you will see a hole through which you may access the rest of the grease and the solids. Be sure to lower the hose all the way to the bottom of the Trapzilla unit so that solids may be entirely removed.

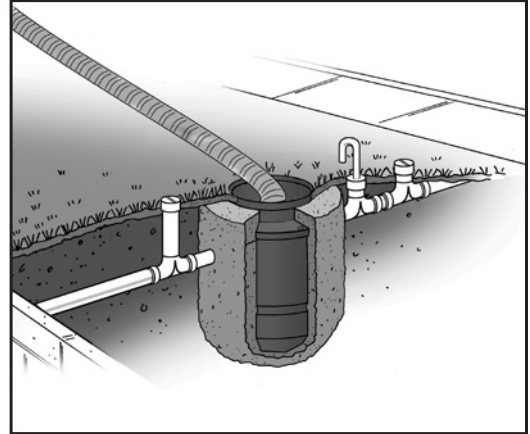

Note:

1. **DO NOT** use mechanical crust breaking devices to break down any mat that has formed inside the Trapzilla unit.
2. Remove the four brass nuts from the bolts and fully remove the lid to pump out.
3. It is not necessary to remove adapter lid (ring) to pump out Trapzilla.
4. If necessary, use a water hose with spray nozzle to rinse off inside of unit.
5. **DO NOT** use grinding augers in maintenance of the Trapzilla unit.

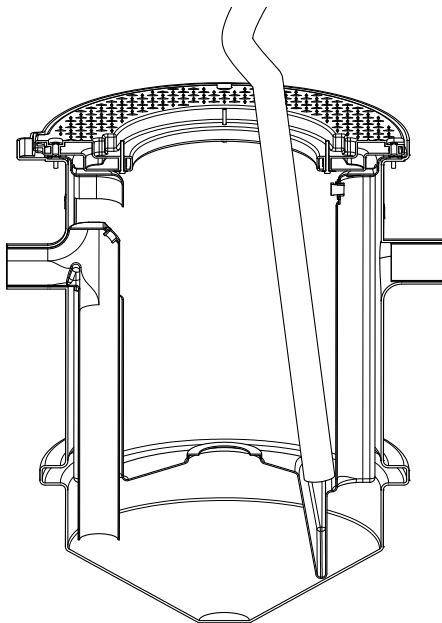

Begin by pumping grease from upper chamber, until you can see the entire horizontal baffle.
May be necessary to use water hose to rinse out parts of upper chamber.

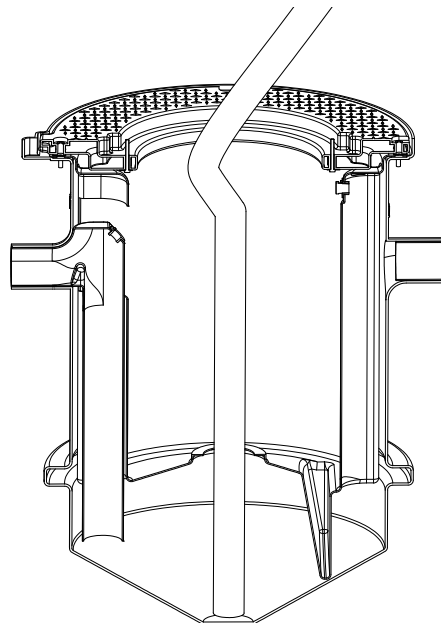

Drop hose into lower chamber through hole in horizontal baffle, pumping out all liquids and solids remaining.
Again, it may be necessary to use water hose to rinse out lower chamber.



Limited Warranty & Remedy

Thermaco, Inc. warrants to the original user that the products manufactured by it delivered with this warranty shall be free from material defects in workmanship and materials for a period of 12 months from the date of invoice to the distributor (if sold by an authorized Thermaco distributor) or the date of invoice to the purchaser (if sold directly by Thermaco, Inc.), but in no event longer than 15 months from date of shipment from Thermaco's production facility.

Any claim must be made in writing to Thermaco at 646 Greensboro Street, Asheboro, NC 27203 promptly after discovery of the defect and within the applicable warranty period. The product must be delivered, pre-paid, to Thermaco, together with proof of purchase and a return authorization number issued by Thermaco. If Thermaco determines upon examination that the component is defective and that the warranty conditions are met, Thermaco's sole obligation under this warranty, and the purchaser's sole and exclusive remedy, is the repair or replacement, at Thermaco's option, of the defective component, including parts and labor. The replacement will be furnished F.O.B. point of shipment. If Thermaco determines that the component is not defective or that the other conditions of this warranty are not met, then any return of such part to the purchaser shall be at purchaser's cost.

This warranty shall not cover any defect in otherwise covered products resulting directly or indirectly from: (i) failure to properly install, operate or maintain the product in accordance with Thermaco's instructions and procedures, including, without limitation, use in excess of rated flow, use to remove emulsified fats and oils or use that fails to comply with applicable laws, regulations or codes; (ii) damage in transit, handling or installation; (iii) modifications, adjustments, or alterations; (iv) disassembly of critical components other than what is required for prescribed maintenance; or (v) other causes not arising out of defects in workmanship or materials. Thermaco shall not be responsible for damage to products resulting from vault flooding, sewer line back-up, pumping or lift station failure, use in conjunction with unapproved components, ambient water flow or other sources of water damage. This warranty does not cover equipment or parts not manufactured by Thermaco. Purchaser's costs relating to any service, adjustment, removal, repair, packing, or otherwise incurred with respect to the defect prior to submission for warranty are the responsibility of purchaser.

No distributor, sales person or other person is authorized to make any warranty statements on behalf of Thermaco regarding Thermaco products other than as set forth in this warranty. This statement of warranty supercedes any quote, brochure, or other statement or document with respect to warranty of Thermaco products.

EXCEPT AS EXPRESSLY SET FORTH ABOVE, THERMACO, INC. MAKES NO REPRESENTATIONS, WARRANTIES OR GUARANTEES, EITHER EXPRESSED OR IMPLIED, INCLUDING, WITHOUT LIMITATION, AS TO **MERCHANTABILITY OR FITNESS FOR A PARTICULAR PURPOSE**, WHETHER OR NOT THERMACO HAD KNOWLEDGE OF PURCHASER'S PARTICULAR REQUIREMENTS OR NEEDS, OR WITH RESPECT TO ODOR GENERATION OR OTHER INCIDENTALS RELATING TO USE OF THE PRODUCT.

The sole and exclusive remedy with respect to this warranty any other claim relating to defects or any other condition or use of Thermaco products, however caused, and whether such claim is based upon warranty, contract, tort, strict liability or any other theory, is LIMITED to the repair or replacement of the product, excluding labor or any other cost to remove or install said the product or, at Thermaco's option, repayment of the purchase price. IN NO EVENT SHALL THERMACO, INC. BE LIABLE, WHETHER IN CONTRACT, WARRANTY, TORT (INCLUDING NEGLIGENCE), STRICT LIABILITY, INDEMNITY OR ANY OTHER LEGAL THEORY, FOR INCIDENTAL OR CONSEQUENTIAL DAMAGES, OR FOR ANY OTHER LOSS OR COST OF A SIMILAR TYPE. UNDER NO CIRCUMSTANCES WILL THE AGGREGATE LIABILITY OF THERMACO FOR ANY CAUSE OF ACTION RELATED TO THE PRODUCTS COVERED HEREBY EXCEED THE NET PURCHASE PRICE RECEIVED BY THERMACO FOR THE PRODUCTS. Any action or suit by purchaser against Thermaco relating to Thermaco products must be brought within one (1) year of the date of the invoices referenced above. The exclusions and limitations set forth herein are separate and independent from any remedies which purchaser may have hereunder and shall be given full force and effect whether or not any or all such remedies shall be deemed to have failed of their essential purpose.