

What's included?

- 1. Trapzilla99 Grease Interceptor Spec Sheet**
- 2. Trapzilla99 Grease Interceptor Test Report**
- 3. Trapzilla Solids Separator Spec Sheet**
- 4. Trapzilla Sample Port Spec Sheets**
- 5. Flow Control Spec Sheet**
- 6. FOG 2.0 RER-DERM Summary**
- 7. Trapzilla99 Grease Interceptor Manual**

Questions? Need more information?

Contact Seth Markwood

seth@thermaco.com

800-633-4204 x228

PRODUCT FEATURES

Constructed of corrosion resistant materials suitable for installation in virtually any location.

Compact footprint.

Baffle structure retains separated grease increasing retention efficiency of separator.

Included lid rated for foot-traffic only

Includes one SSA-1826 support stand for above-ground installation.

Steel girdle (shipped with unit and assembled in field) required for above ground installations.

Meets (or exceeds) Miami DERM 99% efficiency requirement

SPECIFICATIONS

Construction: _____ Single-Piece Rotationally Moulded Polyethylene Exterior Tank with Inlet/Outlet Inverts secured using Patented Interior Radial Compression Ring

Flow Rating: _____ 100 gpm (6.31 l/s)

Liquid Capacity: _____ 274 gallons (1,037 L)

Grease Capacity: _____ 248.77 Gallons (941 L)
1,826 lbs. (828 Kg)

Solids Capacity: _____ 74 gallons (280 L)

Inlet/Outlet: _____ 4" (101 mm)

Efficiency: _____ 99.2%

Product Weight: _____ 375 lbs. (171 Kg)

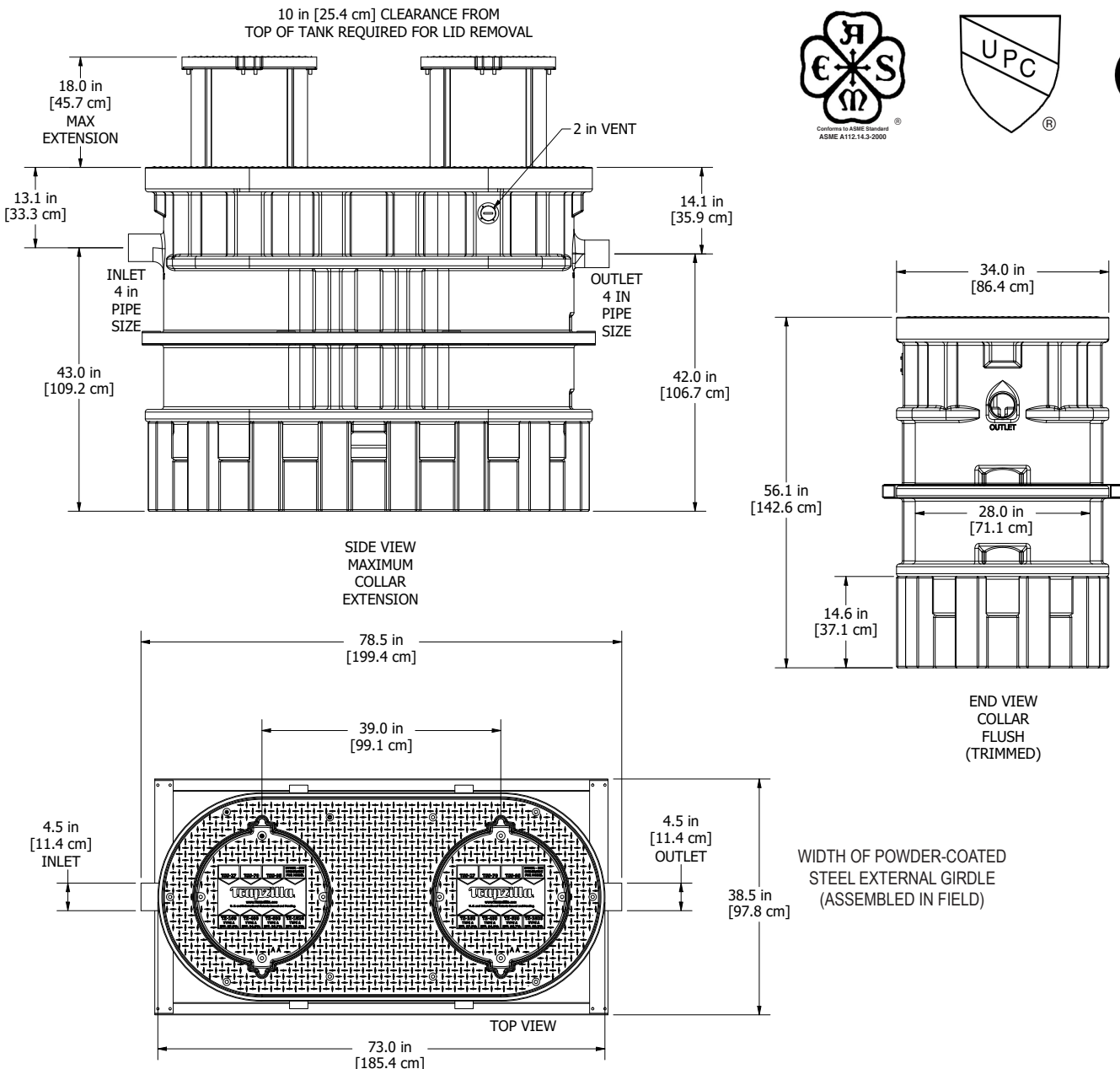



Trapzilla99® Grease Interceptor

TZ-1826-SSA Specifications

NOTES

1. READ instruction manual included with system before installing/operating.
2. Unit requires 6" (15.24 cm) of clearance all the way around the lid from walls or other structures to allow for servicing.
3. Make piping connections with rubber "No Hub" connectors.
4. Keep outlet piping as straight as possible. Use only "sweep" connections.
5. Install vent on outlet piping.
6. If installing in conjunction with other Trapzilla products, include cleanout port before, after, and/or between each unit.
7. Do not install "P" Trap on outlet connection of tank (unit already has internal gas trap).
8. Do not reduce pipe size on outlet piping
9. Do not pressure test unit.

Equipment must be installed in compliance with all applicable laws, regulations and codes, including plumbing codes. Installation should be performed by a qualified plumbing contractor.

JOB SPECIFICATION

Grease separator(s) shall be Thermaco **Trapzilla** hydromechanical grease interceptor system(s) as manufactured by Thermaco, Inc., Asheboro, North Carolina as noted on plans.

SEPARATOR SPECIFICATIONS

Furnish and install _____ Thermaco Trapzilla Model No. TZ-1826-SSA, rotationally molded polyethylene grease interceptor(s) for above ground installation, shall be PDI-G 101 and ASME A112.14.3 rated at 100 GPM (6.31 l/s) with 248.77 Gallons (941 L) / 1,826 lbs. (828 Kg) of total grease storage capacity with flat separation efficiency curve capable of holding 90% of volume in free-floating oils at capacity, with removable cover for grease and solids removal access, integral anti-flotation anchor ring for in-ground installation, integral horizontal baffle, laminar inlet flow diverter, integral vessel vent, separate storage compartments for oil and heavier than water solids, a unitary tank body and 4" (101mm) inlet/outlet structures without gasket interfaces, utilizing an interior radial compression ring conjoining invert to tank outlet/inlet structures without bulkhead fittings and/or gaskets, invert top and bottom secured attachment points, sloping conical bottom for solids retention, integral sewer gas trap, and a fully removable polyethylene self-positioning cover with sealed thread fasteners. Includes dual-entry extension collar assembly, linear low-density rotationally molded polyethylene for field adjustability to optimal installation depth. Included support stand manufactured out of linear low-density rotationally molded polyethylene. Included external girdle manufactured out of powder-coated steel.

SUBMITTAL OPTIONS

- 6" (150mm) Inlet/Outlet - Model# TZ-1826-SSA-6
- TZSP-40 Sampling Port with 4" Inlet/Outlet, 0.5" fall
No support stand available, sampling port must be buried (may require TZSP-40-ECA) or hung using pipe hangers
- TZSP-48 Sampling Port with 4" Inlet/Outlet, 7.8" fall
No support stand available, sampling port must be buried (may require TZSP-40-ECA) or hung using pipe hangers
- TSS-95-SSA Solids Interceptor
- VFCA-100 Vented Flow Control Assembly for installation at plumbing fixture level to limit flow to 100 gpm for installations with head height greater than 6'
- MFSH-44 Molded Flow Splitter Assembly for evenly diverting flow to two separate 4" Trapzilla units
- MFSH-66 Molded Flow Splitter Assembly for evenly diverting flow to two separate 6" Trapzilla units



TEST REPORT

5001 East Philadelphia Street
Ontario, California – USA 91761-2816
Ph: 909.472.4100 | Fax: 909.472.4243
<http://www.iapmortl.org>

Report Number: 907-15010

Report Issued: March 2nd, 2015

Client: Thermaco
646 Greensboro St.
Asheboro, NC 27203

Project Number: 24390

Contact: Bill Batten

Source of Samples: Samples were manufactured at the Thermaco facility in Asheboro, North Carolina and witnessed tested by Dale E. Holloway of IAPMO R&T Lab. Samples are manufactured in good condition.

Date of Testing: February 23rd, 2015 through February 27th, 2015

Sample Description: Model “TZ-1826” Grease Interceptor.

Refer to the manufacturer’s drawings and installation instructions for more detailed measurements and information.

Scope of Testing: The above grease interceptor was witnessed tested to meet the requirements of ASME A112.14.3-2000 (Reaffirmed 2004) “Grease Interceptors”.

Conclusion: The “TZ-1826” Grease Interceptor DID COMPLY with the requirements of ASME A112.14.3-2000 (Reaffirmed 2004) for “Grease Interceptors”.

By the signature below, I certify that all the testing and preparation for this report was performed under direct supervision of IAPMO R&T Lab, unless otherwise stated.

Witness tested and reported by,

Dale E. Holloway, Regional Technical Manager
IAPMO R&T Lab

TZ-1826 Grease Interceptor					INCREMENTAL				ACCUMULATED			
Test No.	Grease Sink	Water Sink	Drop Time (sec)	Flow Rate (GPM)	Lbs added	Lbs skimmed	Lbs retained	Efficiency (%)	Lbs added	Lbs skimmed	Lbs retained	Efficiency (%)
90	2	1	112	101.8	20	0.35	19.65	98.3%	1800	12.41	1787.59	99.3%
91	1	2	111	102.7	20	0.48	19.52	97.6%	1820	12.89	1807.11	99.3%
92	2	1	111	102.7	20	0.38	19.62	98.1%	1840	13.27	1826.73	99.3%
93	1	2	111	102.7	20	19.99	0.01	0.1%	1860	33.26	1826.74	99.2%
94	2	1	111	102.7	20	9.35	10.65	53.3%	1880	42.61	1837.39	97.7%

Performance Requirement

Maximum Capacity

PRODUCT FEATURES

Constructed of corrosion resistant materials suitable for installation in virtually any location.

Compact footprint.

Baffle structure retains separated grease increasing retention efficiency of separator.

Included lid rated for foot-traffic only

Includes one SSOP-70/95 support stand for above-ground installation.

SPECIFICATIONS

Construction: _____ Single-Piece Rotationally Moulded Polyethylene Exterior Tank with Inlet/Outlet Inverts secured using Patented Interior Radial Compression Ring

Flow Rating: _____ 150 GPM (9.46 l/s)

Liquid Capacity: _____ 95 gallons (359 l)

Solids Capacity: _____ 95 gallons (359 l)

Inlet/Outlet: _____ 4" (101 mm)

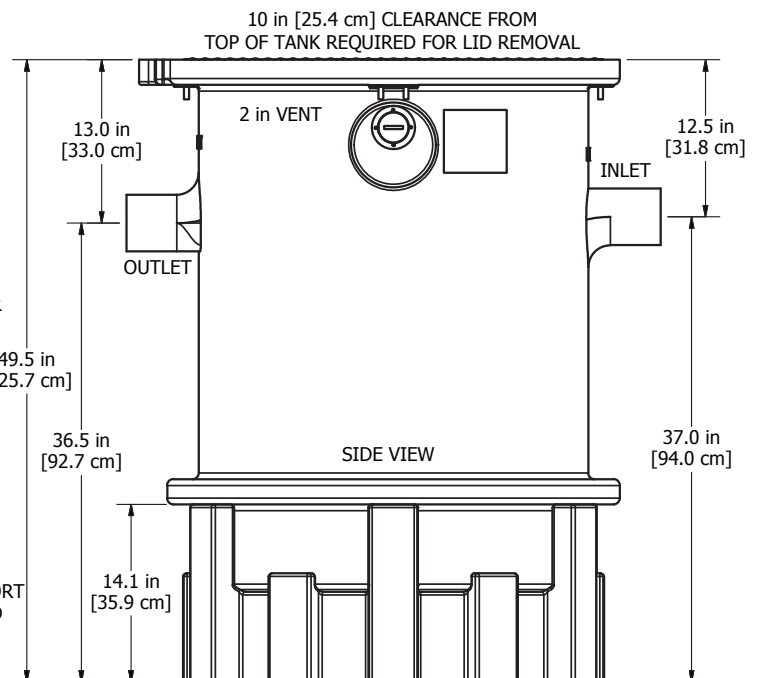
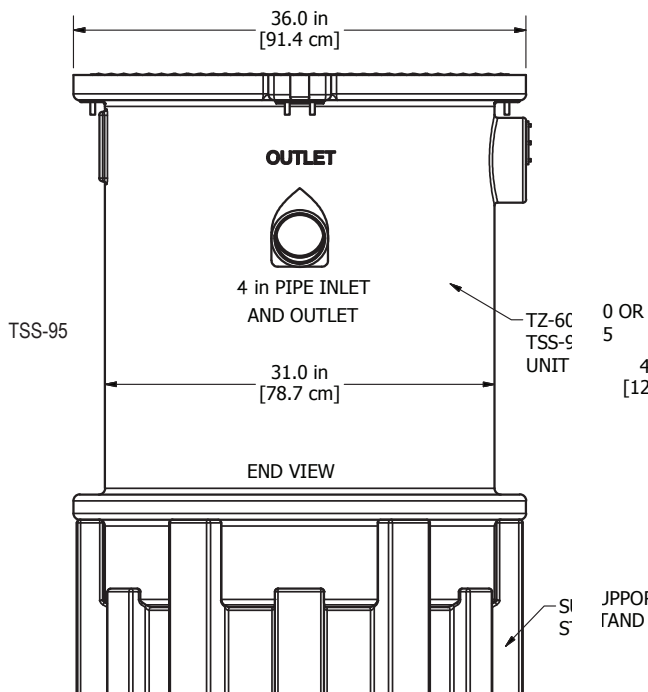
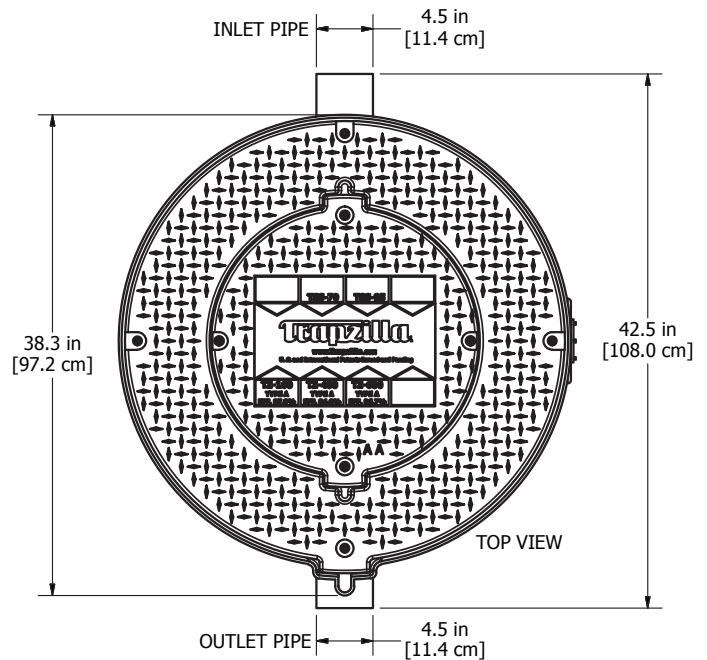



Trapzilla® Solids Separator

TSS-95-SSA Specifications

NOTES

1. READ instruction manual included with system before installing/operating.
2. Unit requires 6" (15.24 cm) of clearance all the way around the lid from walls or other structures to allow for servicing.
3. Make piping connections with rubber "No Hub" connectors.
4. Keep outlet piping as straight as possible. Use only "sweep" connections.
5. Install vent on outlet piping.
6. If installing in conjunction with other Trapzilla products, include cleanout port before, after, and/or between each unit.
7. Do not install "P" Trap on outlet connection of tank (unit already has internal gas trap).
8. Do not reduce pipe size on outlet piping
9. Do not pressure test unit.

Equipment must be installed in compliance with all applicable laws, regulations and codes, including plumbing codes. Installation should be performed by a qualified plumbing contractor.

JOB SPECIFICATION

Solids separator(s) shall be Thermaco Trapzilla solids interceptor system(s) as manufactured by Thermaco, Inc., Asheboro, North Carolina as noted on plans.

SEPARATOR SPECIFICATIONS

Furnish and install _____ Thermaco Trapzilla Model No. TSS-95-SSA, rotationally molded polyethylene solids separator(s) for above ground installation, shall be rated at 150 gpm (9.46 l/s) with 95 gallons (359 l) of total solids storage capacity, with removable cover for solids removal access, integral anti-flotation anchor ring for in-ground installation, laminar inlet flow diverter, integral vessel vent, a unitary tank body and 4" (101 mm) inlet/outlet structures without gasket interfaces, utilizing an interior radial compression ring conjoining invert to tank outlet/inlet structures without bulkhead fittings and/or gaskets, sloping conical bottom, integral sewer gas trap, and a fully removable polyethylene self-positioning cover with sealed thread fasteners. Included support stand manufactured out of linear low-density rotationally molded polyethylene.

SUBMITTAL OPTIONS

- 6" (150mm) Inlet/Outlet - Model# TSS-95-SSA-6
- TZSP-40 Sampling Port with 4" Inlet/Outlet, 0.5" fall
No support stand available, sampling port must be buried (may require TZSP-40-ECA) or hung using pipe hangers
- TZSP-48 Sampling Port with 4" Inlet/Outlet, 7.8" fall
No support stand available, sampling port must be buried (may require TZSP-40-ECA) or hung using pipe hangers
- VFCA-75 Vented Flow Control Assembly for installation at plumbing fixture level to limit flow to 75 gpm for installations with head height greater than 6'
- MFSH-44 Molded Flow Splitter Assembly for evenly diverting flow to two separate 4" Trapzilla units
- MFSH-66 Molded Flow Splitter Assembly for evenly diverting flow to two separate 6" Trapzilla units
- FTCA-22 Fabricated Top Cover Assembly with 22" (55.9 cm) diameter diamond plate aluminum surface for heavy duty foot-traffic, pallet jacks, food carts etc. Replaces standard 22" STC-TZ-22 Cover (not rated for vehicle traffic)
- FTCA-36 Fabricated Top Cover Assembly with 36" (91.4 cm) diameter diamond plate aluminum surface for heavy duty foot-traffic, pallet jacks, food carts etc. Replaces Adapter Ring and Standard Cover (not rated for vehicle traffic)
- H20/Traffic Rated Installation, see [link](#) for installation drawings

FEATURES:

- Constructed of corrosion resistant materials suitable for installation in virtually any location.
- Compact footprint.
- 0.5" (12.7 mm) fall for horizontal filling access.
- Optional field-modifiable extension collar available to bring lid up to grade.
- Patent-pending flume technology narrows and accelerates incoming flows allowing sampling despite lack of substantial fall gradient.

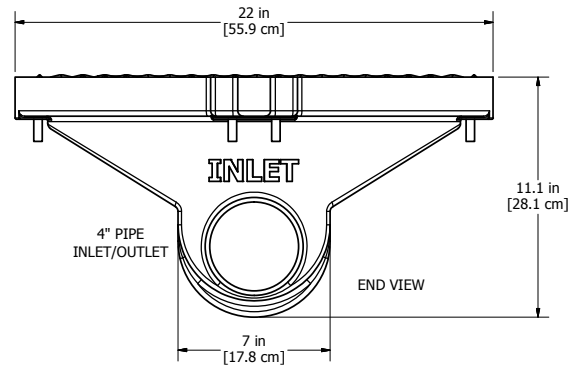
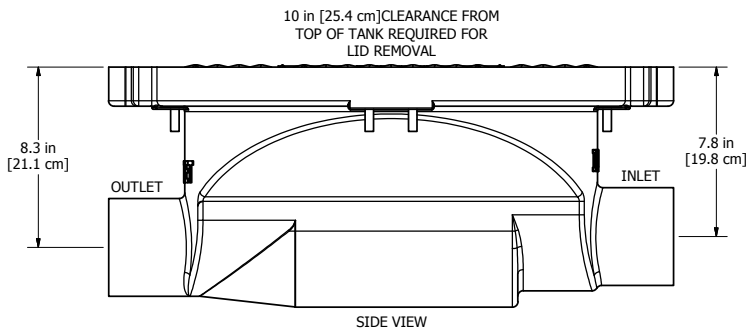
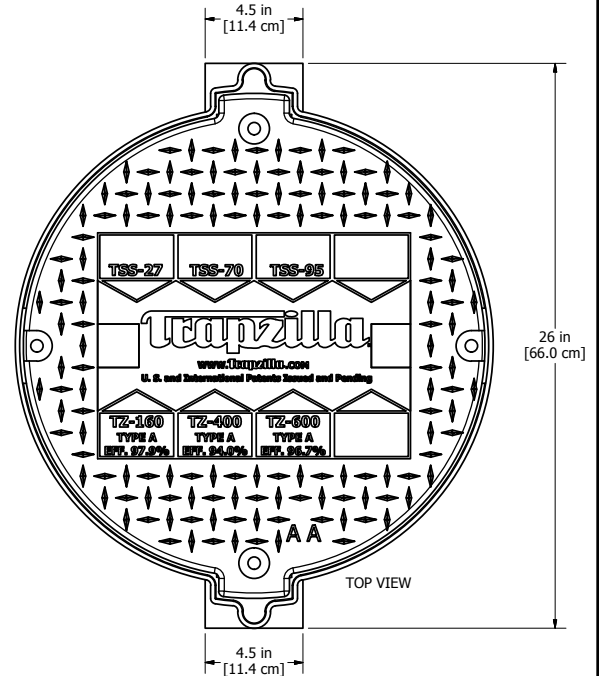

TECHNICAL DATA

Materials: _____ Rotationally Molded Polyethylene

Inlet/Outlet Size: _____ 4" (102 mm)

Fall Gradient: _____ 0.5" (12.7 mm)

INSTALLATION INFORMATION

Suggested Minimum Footprint Dimensions

Trapzilla Sample Ports require 6" (15.24 cm) of clearance all the way around the lid from walls or other structures to allow for servicing.

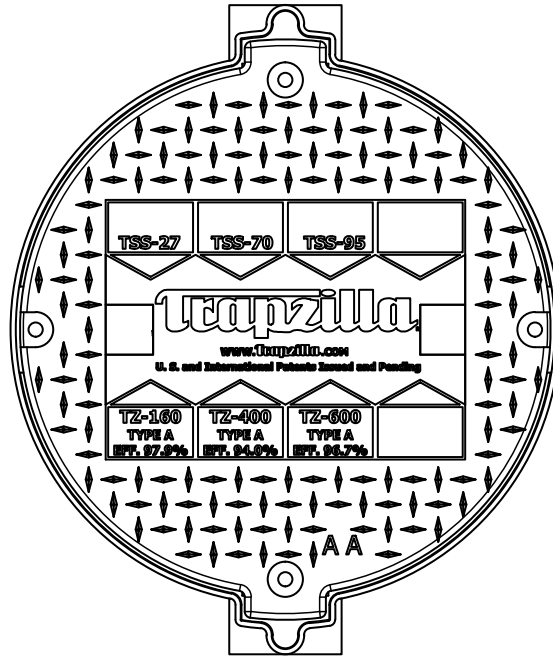

READ instruction manual included with system before doing anything.

Install unit allowing for the minimum clearances shown.

Make piping connections with rubber "No Hub" connectors.

Keep outlet piping as straight as possible. Use only "sweep" connections.

If installing in conjunction with other Thermaco products, include cleanout port between each unit.

DO NOT reduce pipe size on outlet piping.

DO NOT install "P" trap on outlet connection.

NOTE: Drawing for reference only. Equipment must be installed in compliance with all applicable laws, regulations and codes, including plumbing codes. Installation should be performed by a qualified plumber.

Job Specification:

Wastewater Sampling Port(s) shall be Thermaco **Trapzilla** Sampling Port as manufactured by Thermaco, Inc., Asheboro, North Carolina as noted on plans.

Sampling Port Specifications:

Furnish and install ___ Thermaco **Trapzilla** Model No. TZSP-40, linear low-density rotationally molded polyethylene wastewater sampling port(s) for below-ground installation with fully removable polyethylene self-positioning keyed cover equipped with brass fasteners for sampling access, 0.5" (12.7 mm) fall, 4" (102 mm) Inlet/Outlet interior diameter, and patent-pending flume technology for preventing sediment build-up and allowing horizontal filling access.

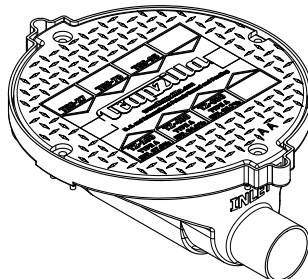

FEATURES:

- Constructed of corrosion resistant materials suitable for installation in virtually any location.
- Compact footprint.
- 7.8" (198 mm) fall to meet vertical waterfall filling access.
- Optional field-modifiable extension collar available to bring lid up to grade.
- Patent-pending flume technology narrows and accelerates incoming flows preventing build-up of sediment in inlet.

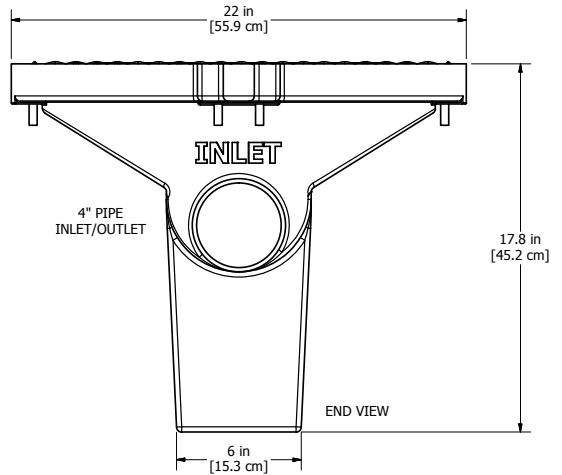
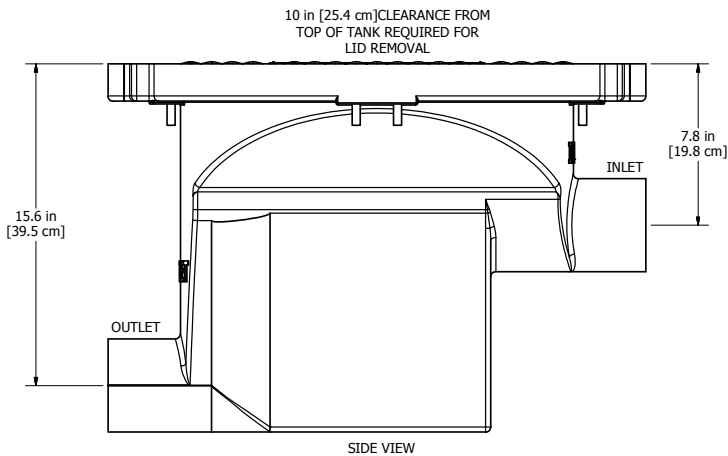
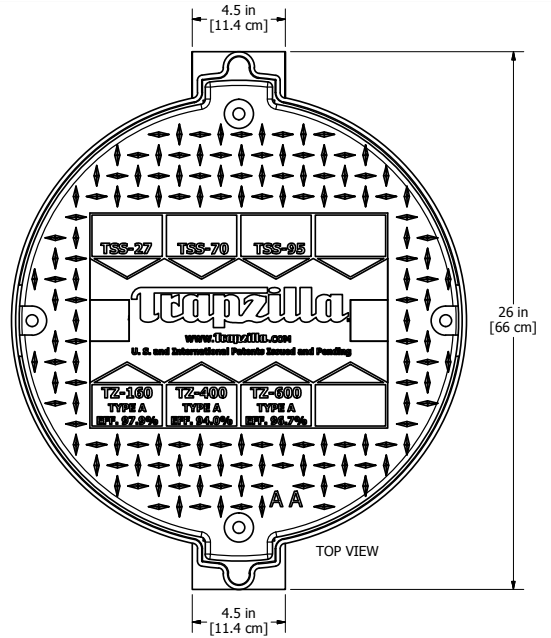

TECHNICAL DATA

Materials: _____ Rotationally Molded Polyethylene
 Inlet/Outlet Size: _____ 4" (102 mm)
 Fall Gradient: _____ 7.8" (198 mm)

INSTALLATION INFORMATION

Suggested Minimum Footprint Dimensions

Trapzilla Sample Ports require 6" (15.24 cm) of clearance all the way around the lid from walls or other structures to allow for servicing.

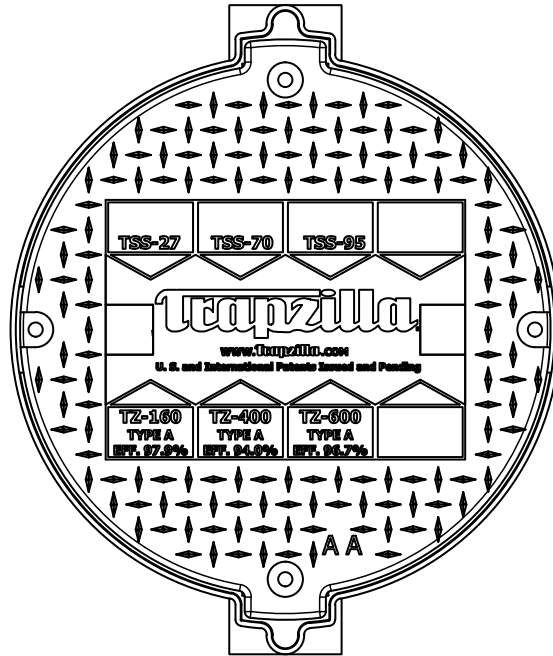

READ instruction manual included with system before doing anything.

Install unit allowing for the minimum clearances shown.

Make piping connections with rubber "No Hub" connectors.

Keep outlet piping as straight as possible. Use only "sweep" connections.

If installing in conjunction with other Thermaco products, include cleanout port between each unit.

DO NOT reduce pipe size on outlet piping.

DO NOT install "P" trap on outlet connection.

NOTE: Drawing for reference only. Equipment must be installed in compliance with all applicable laws, regulations and codes, including plumbing codes. Installation should be performed by a qualified plumber.

Job Specification:

Wastewater Sampling Port(s) shall be Thermaco **Trapzilla** Sampling Port as manufactured by Thermaco, Inc., Asheboro, North Carolina as noted on plans.

Sampling Port Specifications:

Furnish and install ___ Thermaco **Trapzilla** Model No. TZSP-48, linear low-density rotationally molded polyethylene wastewater sampling port(s) for below-ground installation with fully removable polyethylene self-positioning keyed cover equipped with brass fasteners for sampling access, 7.8" (198mm) fall for vertical waterfall filling access, 4" (102 mm) Inlet/Outlet interior diameter, and patent-pending flume technology for preventing sediment build-up in inlet.

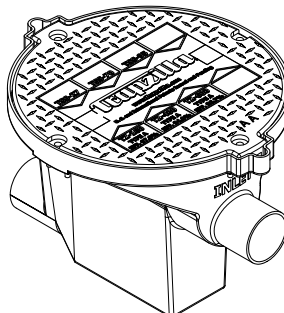

FLOW CONTROL LOCATION- FOR REFERENCE ONLY

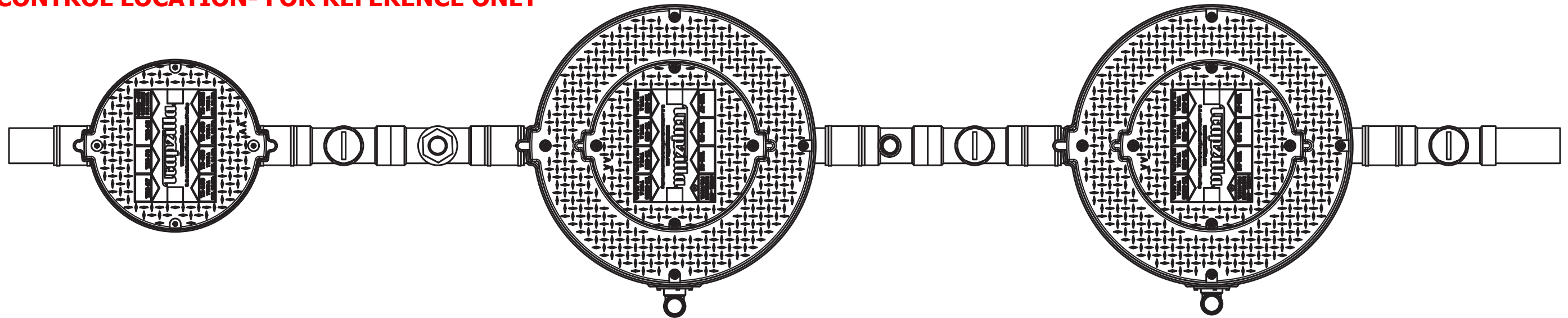

FLOW CONTROL

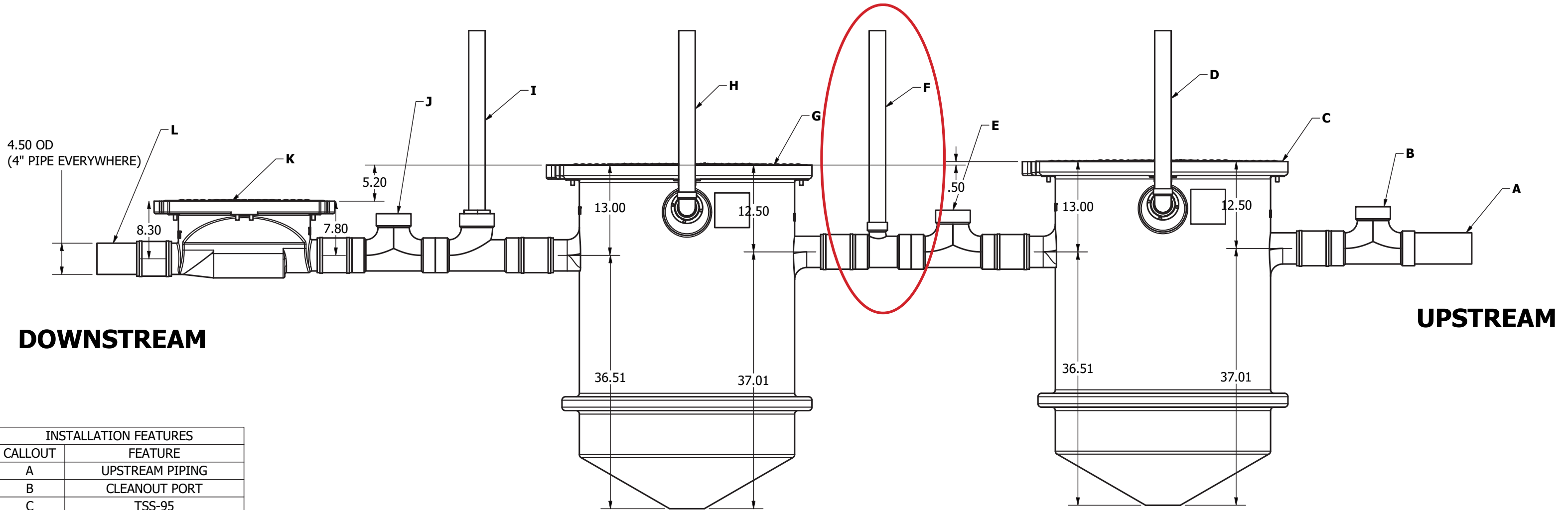

DOWNSTREAM

UPSTREAM

INSTALLATION FEATURES	
CALLOUT	FEATURE
A	UPSTREAM PIPING
B	CLEANOUT PORT
C	TSS-95
D	TSS-95 VESSEL VENT
E	CLEANOUT PORT
F	VENTED FLOW CONTROL
G	TZ-525
H	TZ-525 VESSEL VENT
I	OUTLET VENT
J	CLEANOUT PORT
K	TZSP-40
L	DOWNSTREAM PIPING

NOTE: THE OPTIONAL VESSEL VENT AND THE VENTED FLOW CONTROL SHOULD NOT BE CONNECTED TO THE FACILITY VENT AND SHOULD BE VENTED INDEPENDENTLY. HOWEVER, THE OUTLET VENT CAN BE CONNECTED TO THE FACILITY VENT.



PO Box 2548, Asheboro, NC 27204-2548
 Phone: (336) 629-4651 • Toll-Free: (800) 633-4204
 info@thermaco.com • www.trapzilla.com

**TSS-95, TZ-525, LHFC, & TZSP-40
 INSTALLED IN SERIES**

LHFC Low Head Flow Control Installation

The Trapzilla unit is shipped with the LHFC-160 (for Model TZ-160) or LHFC-400/600 (for Models TZ-400, TZ-600, TZ-525, and TZ-1826) Low Head Height, Vented Flow Control. This needs to be installed directly at the inlet of the Trapzilla. The Flow Control Vent may be independent direct connect to atmosphere or code-approved air admittance valve. **NEVER CONNECT TO FACILITY VENT.**

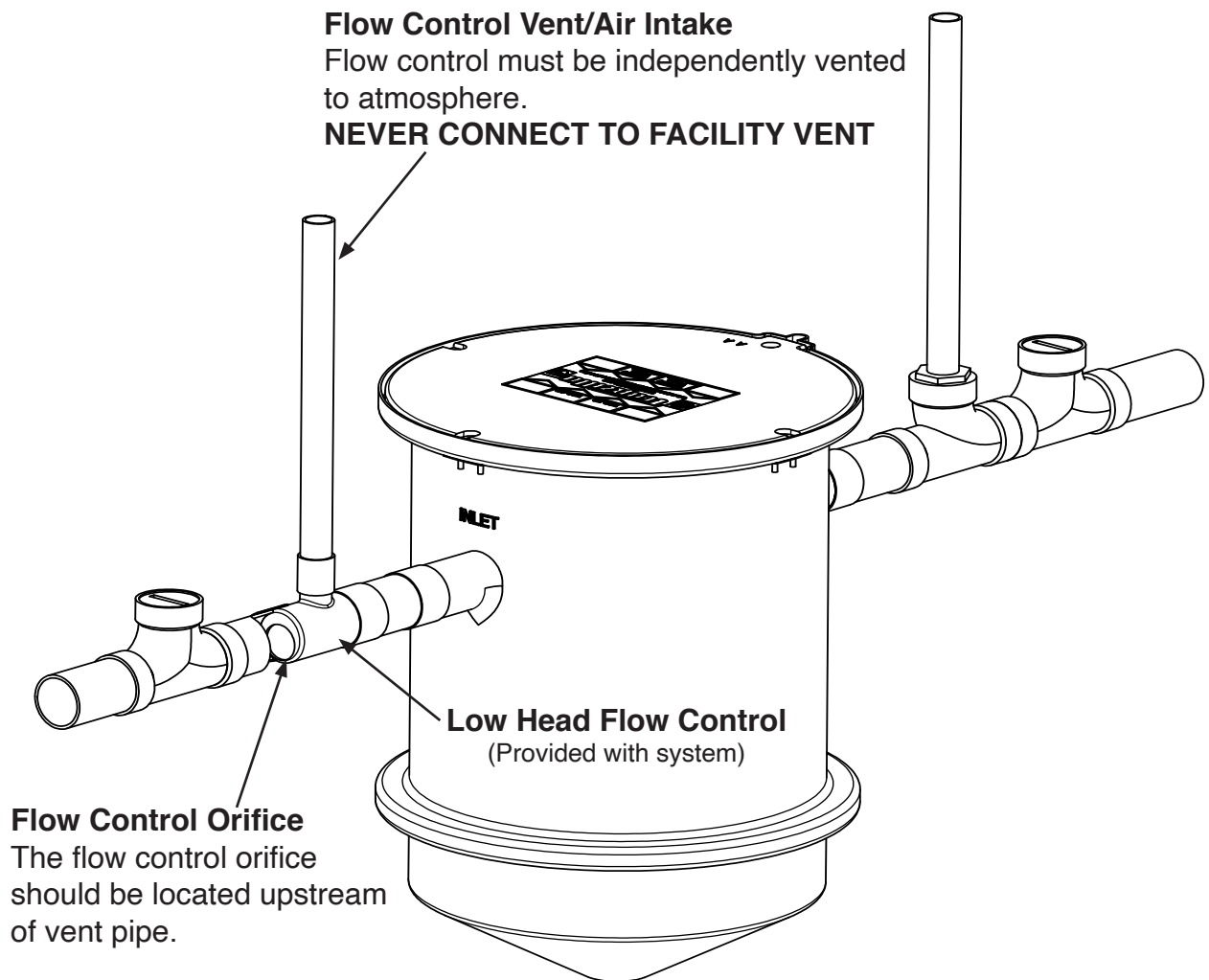

Note: Drawing for reference only. Equipment must be installed in compliance with all applicable laws, regulations and codes, including plumbing codes. Installation should be performed by a qualified plumber.

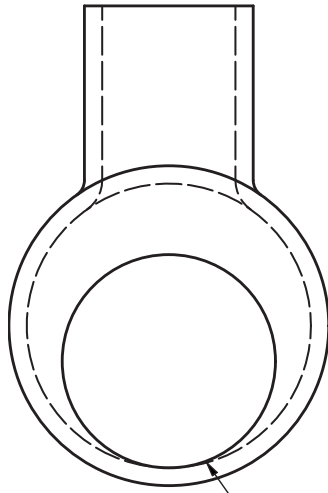

FLOW CONTROL
ORIFICE

Outlet View

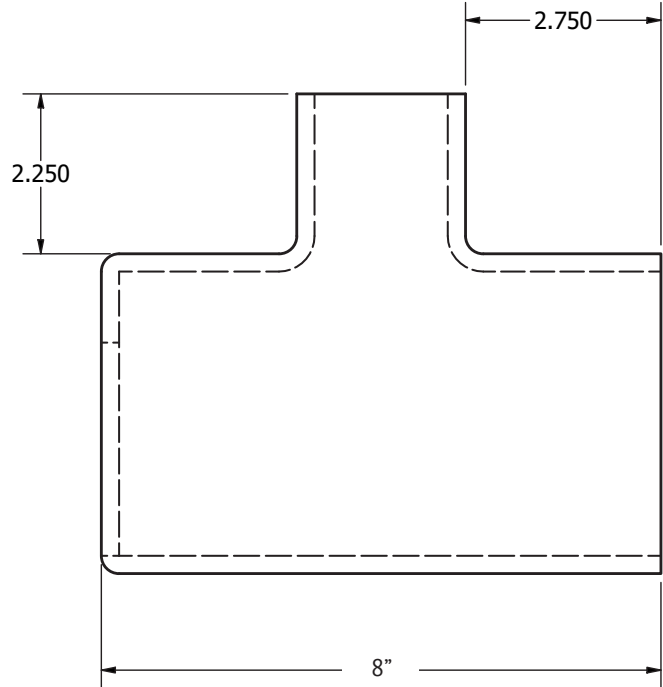

Side View

The Trapzilla grease interceptors ship with an external flow control to be used when necessary. The flow control above is a 4" inlet/outlet flow control.

FOG 2.0 RER-DERM

Hydromechanical FOG Control Device (H-FCD)

Required Information	Tank No. 1	Tank No. 2	Tank No. 3	Tank No. 4
Capacity (gpm)	100			
FOG Load Capacity (lbs) at 99% Efficiency	1826 lbs			
Manufacturer	Thermaco, Inc.			
Model No.	TZ-1826			
3 rd Party Certifier (i.e., PDI, CSA, ASME)	ASME, PDI			
Interceptor Monitoring Alarm Model No.	N/A			
Interceptor Monitoring Device Model No.	N/A			
Solid Separator Make and Model	Thermaco TSS-95			

Updated:6/27/2018

MODEL NUMBERS HAVE TO BE VISIBLE AT THE TIME OF THE DERM/BUILDING INSPECTION

FOG 2.0 RER-DERM

Hydromechanical FOG Control Device (H-FCD)

Required Information	Tank No. 1	Tank No. 2	Tank No. 3	Tank No. 4
Capacity (gpm)	100	100		
FOG Load Capacity (lbs) at 99% Efficiency	1826 lbs	1826 lbs		
Manufacturer	Thermaco, Inc.	Thermaco, Inc.		
Model No.	TZ-1826	TZ-1826		
3 rd Party Certifier (i.e., PDI, CSA, ASME)	ASME, PDI	ASME, PDI		
Interceptor Monitoring Alarm Model No.	N/A	N/A		
Interceptor Monitoring Device Model No.	N/A	N/A		
Solid Separator Make and Model	Thermaco TSS-95			

Updated:6/27/2018

MODEL NUMBERS HAVE TO BE VISIBLE AT THE TIME OF THE DERM/BUILDING INSPECTION

FOG 2.0 RER-DERM

Hydromechanical FOG Control Device (H-FCD)

Required Information	Tank No. 1	Tank No. 2	Tank No. 3	Tank No. 4
Capacity (gpm)	100	100	100	
FOG Load Capacity (lbs) at 99% Efficiency	1826 lbs	1826 lbs	1826 lbs	
Manufacturer	Thermaco, Inc.	Thermaco, Inc.	Thermaco, Inc.	
Model No.	TZ-1826	TZ-1826	TZ-1826	
3 rd Party Certifier (i.e., PDI, CSA, ASME)	ASME, PDI	ASME, PDI	ASME, PDI	
Interceptor Monitoring Alarm Model No.	N/A	N/A	N/A	
Interceptor Monitoring Device Model No.	N/A	N/A	N/A	
Solid Separator Make and Model	Thermaco TSS-95			

Updated:6/27/2018

MODEL NUMBERS HAVE TO BE VISIBLE AT THE TIME OF THE DERM/BUILDING INSPECTION

FOG 2.0 RER-DERM

Hydromechanical FOG Control Device (H-FCD)

Required Information	Tank No. 1	Tank No. 2	Tank No. 3	Tank No. 4
Capacity (gpm)	100	100	100	100
FOG Load Capacity (lbs) at 99% Efficiency	1826 lbs	1826 lbs	1826 lbs	1826 lbs
Manufacturer	Thermaco, Inc.	Thermaco, Inc.	Thermaco, Inc.	Thermaco, Inc.
Model No.	TZ-1826	TZ-1826	TZ-1826	TZ-1826
3 rd Party Certifier (i.e., PDI, CSA, ASME)	ASME, PDI	ASME, PDI	ASME, PDI	ASME, PDI
Interceptor Monitoring Alarm Model No.	N/A	N/A	N/A	N/A
Interceptor Monitoring Device Model No.	N/A	N/A	N/A	N/A
Solid Separator Make and Model	Thermaco TSS-95		Thermaco TSS-95	

Updated:6/27/2018

MODEL NUMBERS HAVE TO BE VISIBLE AT THE TIME OF THE DERM/BUILDING INSPECTION



Installation & Maintenance Instructions For Trapzilla99® TZ-1826

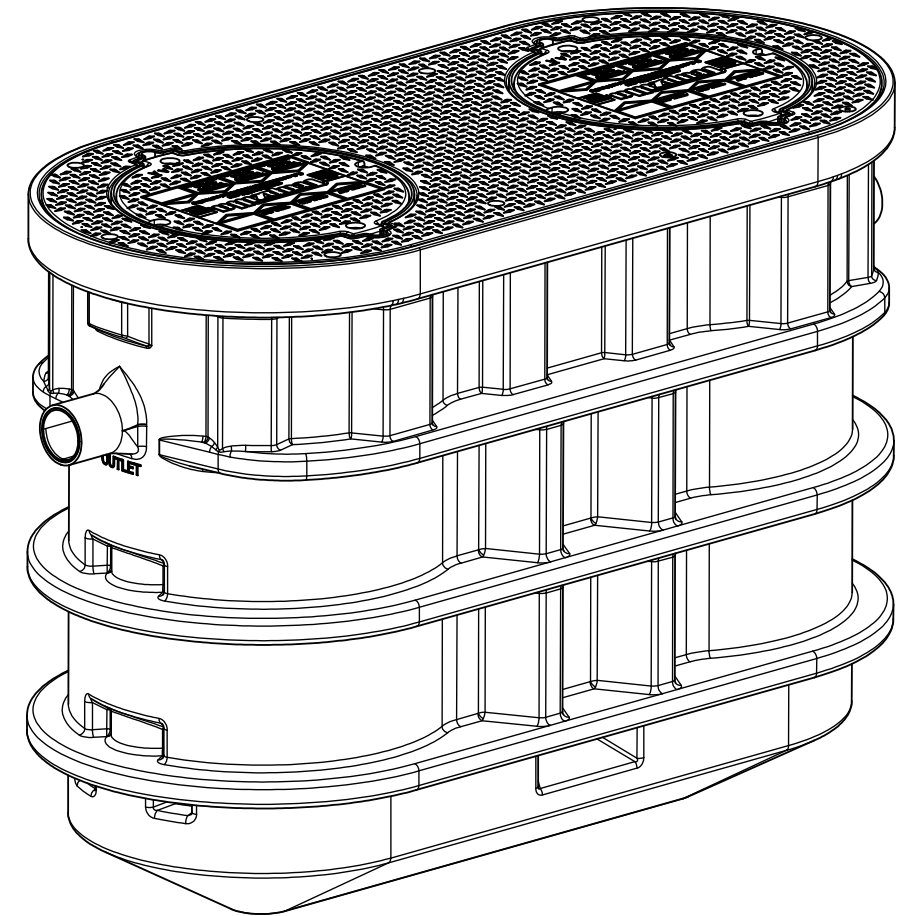

Conforms to ASME Standard
ASME A112.14.3-2000
Please consult Thermaco, Inc. for specific models tested,
certified and/or listed by these organizations.

For additional information on Trapzilla or other Thermaco products,
please visit www.trapzilla.com or call at 1-800-633-4204.

**Please consult Thermaco, Inc. for specific models tested,
certified and/or listed by these organizations.*

Copyright ©2019 Trapzilla® Thermaco, Inc. • P.O.Box 2548 • Asheboro, NC 27204
Toll Free: (800) 633-4204 • Phone: (336) 629-4651 • Fax: (336) 626-5739
info@thermaco.com • www.trapzilla.com

Contents

1. System Overview..... 3

2. Models and Options..... 4

 2.1 Models 4

 2.2 Options 5

3. Plumbing Installation 6

 3.1 Plumbing Considerations Prior to Installation..... 6

 3.1.1 Locating the Unit..... 6

 3.1.2 Inlet/Outlet Piping 6

 3.1.3 Flow Controls..... 6

 3.1.4 Venting the Outlet 6

 3.1.5 High Head Height Applications Over Six (6) Feet (1.95 m) 6

 3.2 Vessel Vent Connection..... 7

 3.3 Plumbing Configurations 8

 3.3.1 One TZ-1826 8

 3.3.2 Installing Multiple Trapzilla Units in Parallel..... 9

 3.3.3 Installing Multiple Trapzilla Units in Series..... 10

4. Above-Ground Installation 11

 4.1 Components for Above-Ground Installations..... 11

 4.2 Instructions for Assembling and Attaching External Brace 12

 4.3 Instructions for Installing Multiple Trapzilla Units Above-Ground..... 12

 4.3.1 Installing TZ-1826-SSA with TSS-95-SSA in Series 12

 4.3.2 Construction of Riser for TSS-95-SSA installation in series with TZ-1826-SSA..... 13

 4.3.3 Installing Multiple TZ-1826-SSA in Series 13

 4.3.4 Installation of Pipe Hangers with Above-Ground Units 14

5. In-Ground Installation Instructions..... 15

 5.1 Single TZ-1826 Installed In-Ground 15

 5.2 TZ-1826 with Optional ECA-TZ-29 Extension Collars 16

 5.3 Concrete Specifications for In-Ground Installation 17

 5.4 Concrete Calculations for TZ-1826 Models/Components* 17

 5.5 Trimming and Setting the ECA-TZ-18 Single-Piece Extension Collar 18

6. Unit Maintenance..... 20

 6.1 Measuring Grease/Solids Levels..... 20

 6.2 Pumping/Serviceing Unit 21

7. Limited Warranty and Remedy 22

1. System Overview

The **Thermaco, Inc. Trapzilla99®** series Grease Interceptor collects 99% of free-floating grease & oils contained in kitchen drain water flows. As most food service facility managers already know, grease buildup inside a building’s grease containment system is a major cause of problems due to exterior drain line blockages. These problems jeopardize normal operations as well as create health and safety hazards within the facility itself.

The proper installation of a Trapzilla99 series grease interceptor can reduce or eliminate grease problems and costly sewer surcharges and fines through 99% efficient separation and retention of free-floating grease & oils.

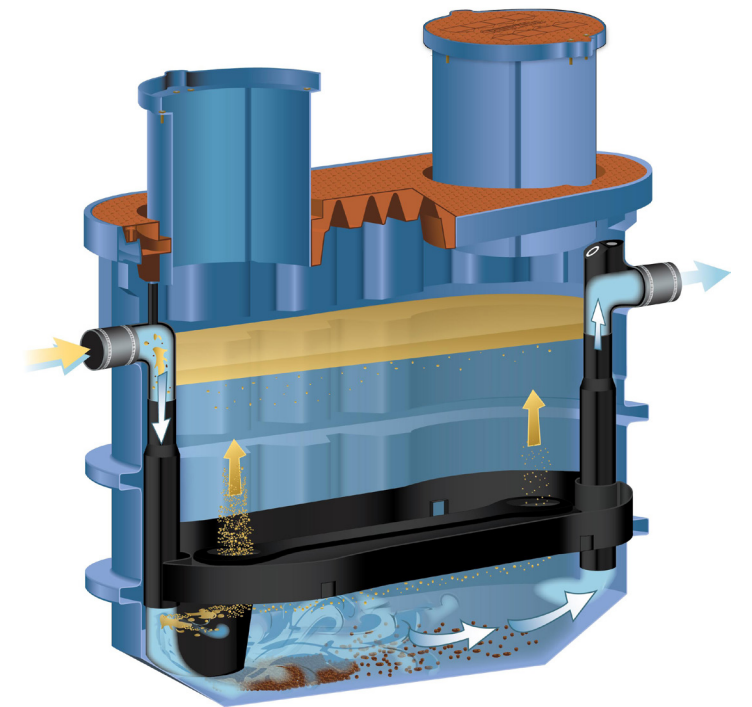

Trapzilla99 grease interceptors offers patented flat separation curve technology. This means that the unit does not lose grease separation efficiency as it fills with retained grease. Thus, the grease interceptor stores large quantities of grease without losing efficiency. The unique compact design of the Trapzilla allows for installation into most facilities. Options are available that enable a Trapzilla unit to be installed on the floor, suspended from the ceiling or in-ground outside the facility.

Trapzilla99 units are designed to treat high flows of kitchen drainwater with large grease storage capacity within a small footprint unit. These units are easy to maneuver into position and just as easy to plumb.

Hydromechanical grease interceptors, automatic recovery units, grease removal devices and other similar plumbing devices receiving kitchen flows from sinks, floor drains, woks and other food bearing sources may generate odors. There are many factors influencing odor evolution and dissemination. These include room ventilation, kitchen menu, ambient temperatures, ware washing practices, grease/oil input, daily input fluid volume, sanitizers, installation plumbing design and product maintenance/upkeep. Odors are usually prevented by good area ventilation, frequent fluid inputs, good product maintenance practices and proper product installation. Additional steps, including aeration, chlorination, pH control, improved area ventilation and additional maintenance may be needed at some sites.

*Devices formerly referred to as grease traps are now called hydromechanical grease interceptors.

2. Models and Options

Thermaco offers different models and options specifically designed to assist the owner/installer meet site conditions while complying with local pretreatment and plumbing code.

2.1 Models

TZ-1826

1,826 pounds of grease storage, PDI and ASME rated at 100 gpm. Equipped with 4" inlet/outlet, 2" vessel vent connection, and 4" Low-Head Flow Control Accessory to limit flow to 100 gpm.

Comes with: Extension Collar Adapter Lid Assembly with two 18" tall extension collars and two 22" diameter lids.

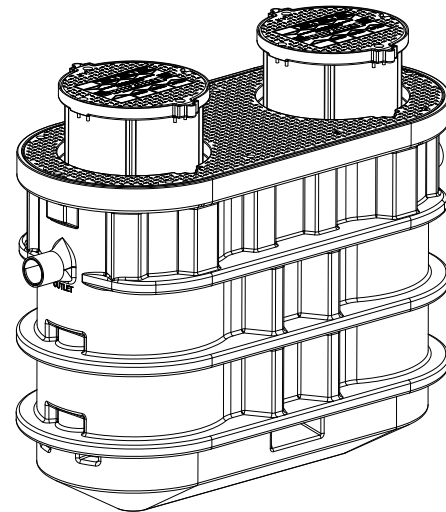

TZ-1826-SSA

1,826 pounds of grease storage, PDI and ASME rated at 100 gpm. Equipped with 4" inlet/outlet, 2" vessel vent connection, and 4" Low-Head Flow Control Accessory to limit flow to 100 gpm.

Comes with: Extension Collar Adapter Lid Assembly with two 18" tall extension collars, two 22" diameter lids, external brace (not pictured) and SSA-1826 Support Stand.

*Models available with 6" Inlet/Outlet, add suffix -6 to model.

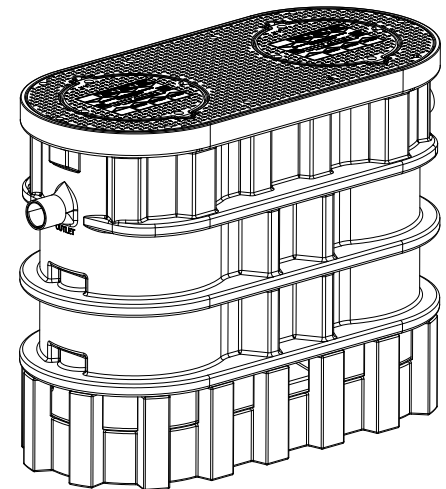

2.2 Options (Some options must be purchased separately)

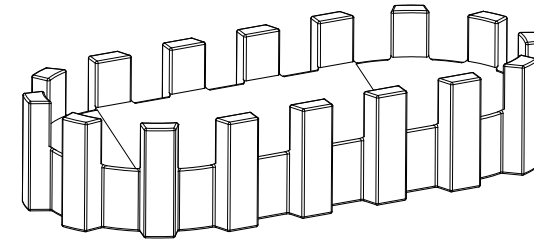

SSA-1826

Support Stand for TZ-1826 for Above-Ground Installations. Must be fully supported, not to be installed over grates.

*Included with TZ-1826-SSA Models

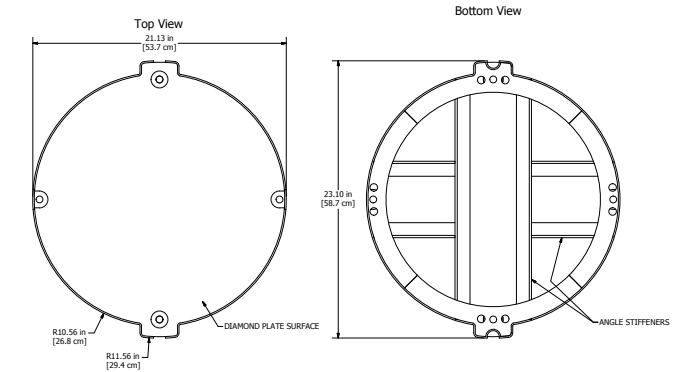

FTCA-22

Optional 22" diameter cover available for In-Ground installations. Provides a non-slip, diamond patterned aluminum replacement for the standard STC-22 cover. Each TZ-1826 would require two (2) FTCA-22 covers.

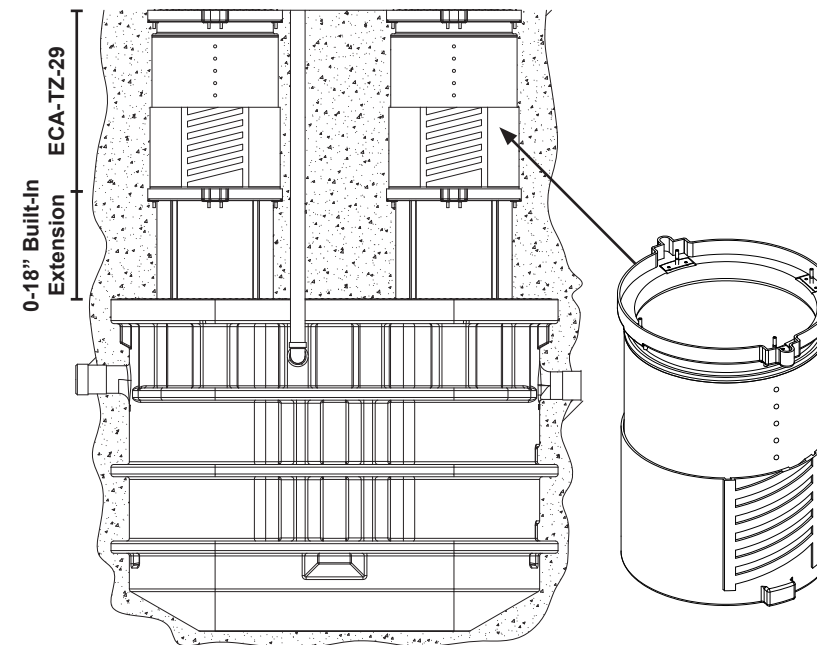

ECA-TZ-29

(purchase separately)

Optional, field-modifiable extension collars available to provide additional depth for existing kitchen drainage piping.

- TZ-1826-ECA Models ship with two (2) built-in 0-18" extension collars.
- ECA-TZ-29 adds 0-29" depth to -ECA model.
- Contact Thermaco before installing any Trapzilla more than 60" below grade from center of outlet pipe or in location where water table will ever rise above bottom of unit.

3. Plumbing Installation

3.1 Plumbing Considerations Prior to Installation

3.1.1 Locating the Unit

The system should be visible and easily accessible for maintenance and inspection. Options are available to install the Trapzilla in a basement, suspended from a ceiling or in-ground in an exterior location. Make sure adequate room is provided around the unit to allow easy access for a pump truck operator. Make sure the height above the Trapzilla access cover is enough to properly service the system.

3.1.2 Inlet/Outlet Piping

The inlet and outlet piping connections require flexible sleeve pipe couplings. Keep outlet piping as straight as possible. Thermaco, Inc. recommends installation of Two-Way Cleanouts on both the Inlet and Outlet of Trapzilla Interceptors and Solids Separators in accordance with all applicable laws, regulations and codes. **These cleanouts should match the size of the Inlet and Outlet Piping (i.e. for 4" Inlet/Outlet piping, a 4" cleanout should be used).** Use only "sweep" connections. Do not reduce the pipe sizing on the outlet piping. Do not install "P" trap on outlet connection of system. (Note: The system already has a internal gas trap)

3.1.3 Flow Controls

Trapzilla systems are supplied with a Low-Head Flow Control module (LHFC). This should be connected to the inlet of the Trapzilla unit in situations where flow rate needs to be restricted to the ASME rated flow or when vented flow control is required by local code.

3.1.4 Venting the Outlet

An outlet vent or approved air admittance valve of at least 1/2 the diameter of the system's outlet connection must be present as close as possible to the Trapzilla outlet to prevent possible siphonage problems. The Vent on the Outlet piping is to be installed in accordance with all applicable laws, regulations and codes. Failure to provide a vent for the system voids Thermaco's Limited Warranty for the system.

3.1.5 High Head Height Applications Over Six (6) Feet (1.95 m)

For installations where there is head height of greater than 6 feet (1.95 meters), Thermaco, Inc. recommends installation of a code-approved Vented Flow Control Assembly (Thermaco VFCA not included with Trapzilla).

Note: Drawing for reference only. Equipment must be installed in compliance with all applicable laws, regulations and codes, including plumbing codes. Installation should be performed by a qualified plumber.

3.2 Vessel Vent Connection

Venting of the tank is recommended by the manufacturer and required for in-door installations.

- Vent the tank through the provided 2" NPT threaded connector on the side of the tank (This vent may be located above the outlet or on the side of the tank depending on model).
- Remove and discard the plug and connect appropriate vent lines as indicated below (for 2" vent connection, use 2" pipe).

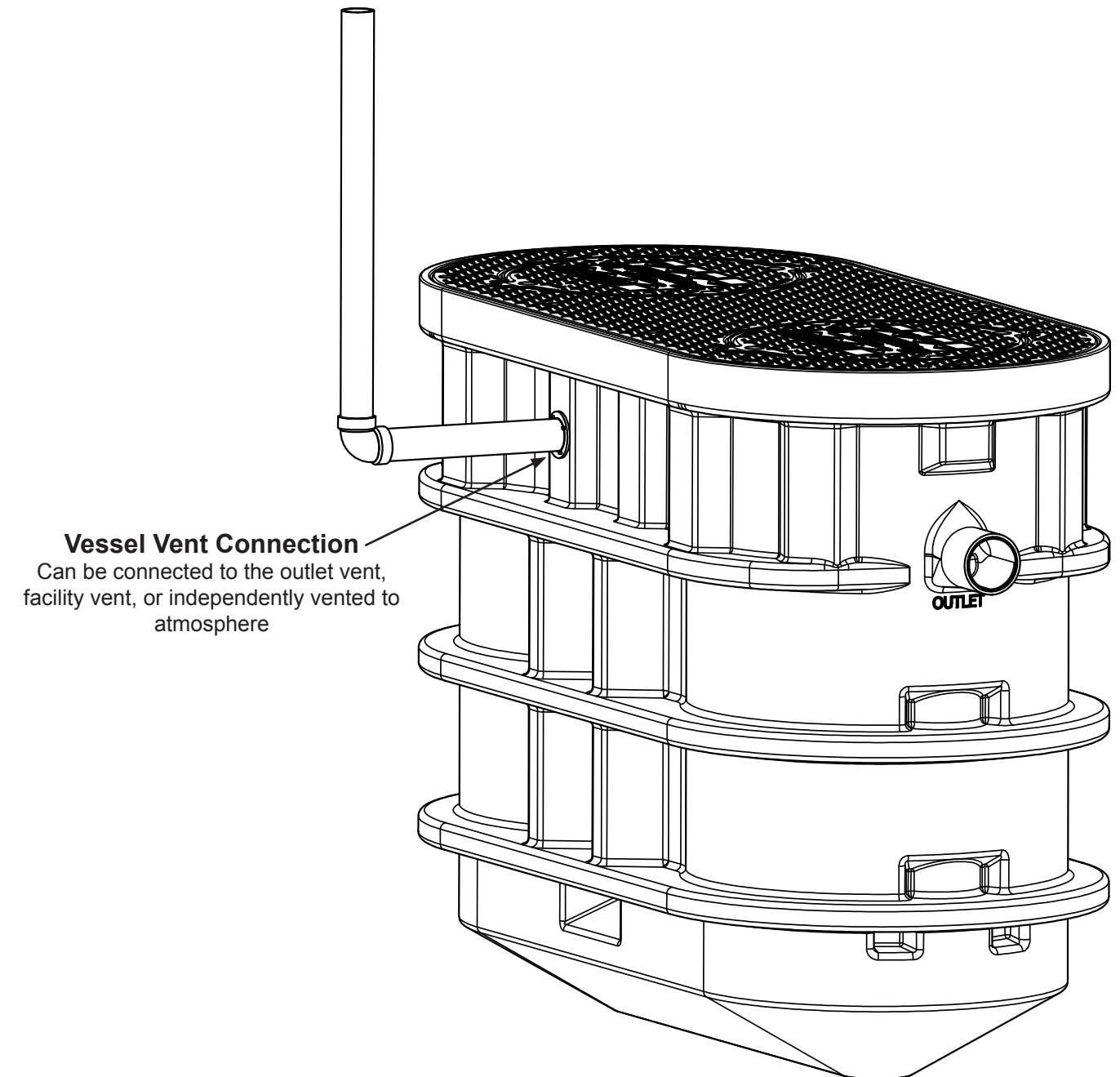

3.3 Plumbing Configurations

3.3.1 One TZ-1826

Each Trapzilla unit is shipped with a Low Head Flow Control module (see LHFC box for additional instructions). When applicable, this needs to be installed to the inlet of the Trapzilla and connected to a code-approved air intake. Thermaco, Inc. recommends installation of Two-Way Cleanouts on both the Inlet and Outlet of Trapzilla® in accordance with all applicable laws, regulations and codes. These cleanouts should match the size of the Inlet and Outlet Piping (i.e. for 4" plumbing, a 4" cleanout should be used). A Vent on the Outlet piping is also to be installed in accordance with all applicable laws, regulations and codes.

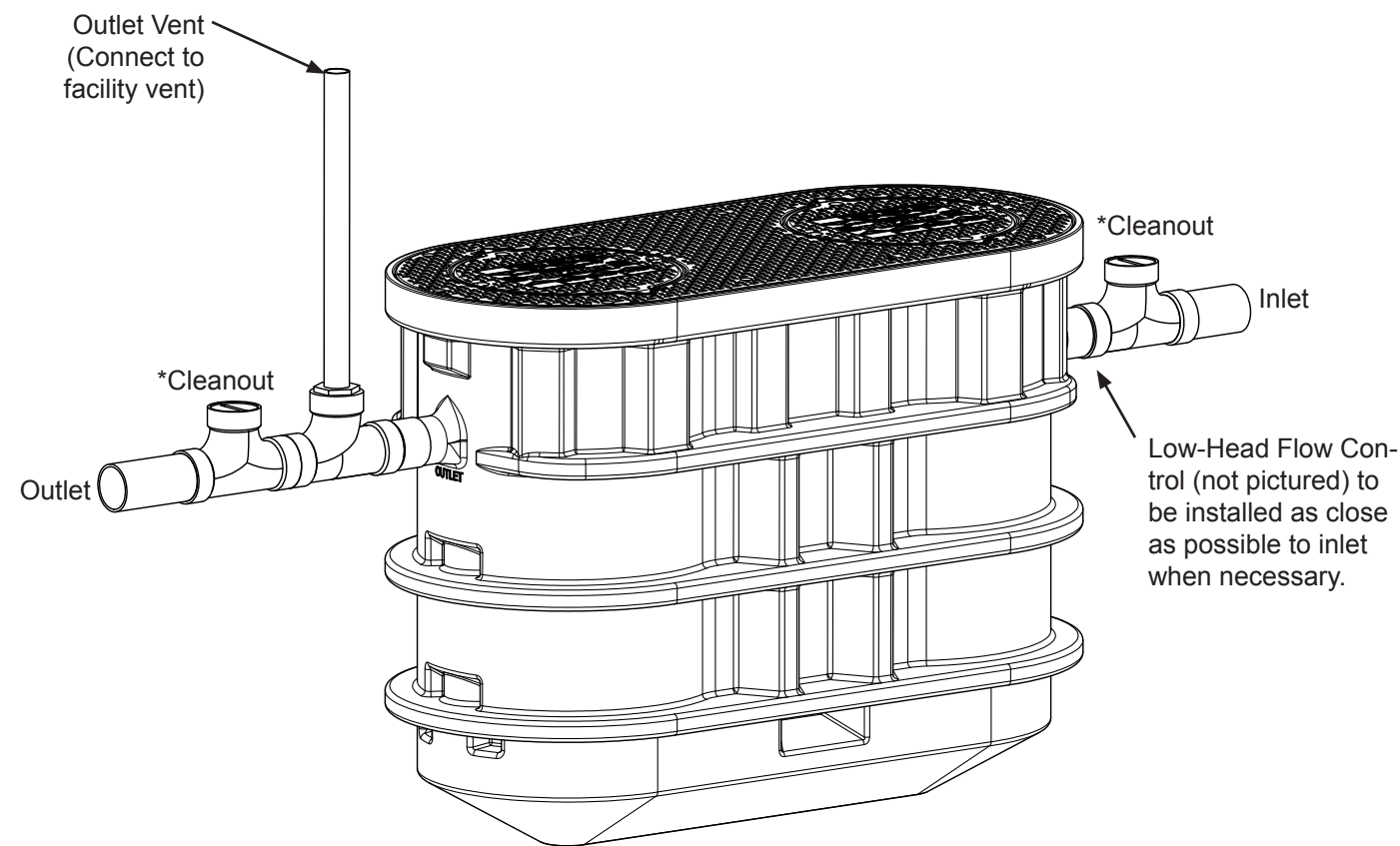

*Use a Two-Way Cleanout before and after all Trapzilla Installations

3.3.2 Installing Multiple Trapzilla Units in Parallel

Trapzilla Grease Interceptors should be installed in parallel with a Trapzilla Flow Splitter (MFSH-44 or MFSH-66) diverting the flow. Place Two-Way Cleanouts before, between and after the units as shown below, including before and after the flow splitter. Make sure to connect an outlet vent after each Trapzilla Grease Interceptor. A Low Head Flow Control (LHFC) is shipped with each unit, and if needed should only be installed after the first Cleanout and before the Flow Splitter.

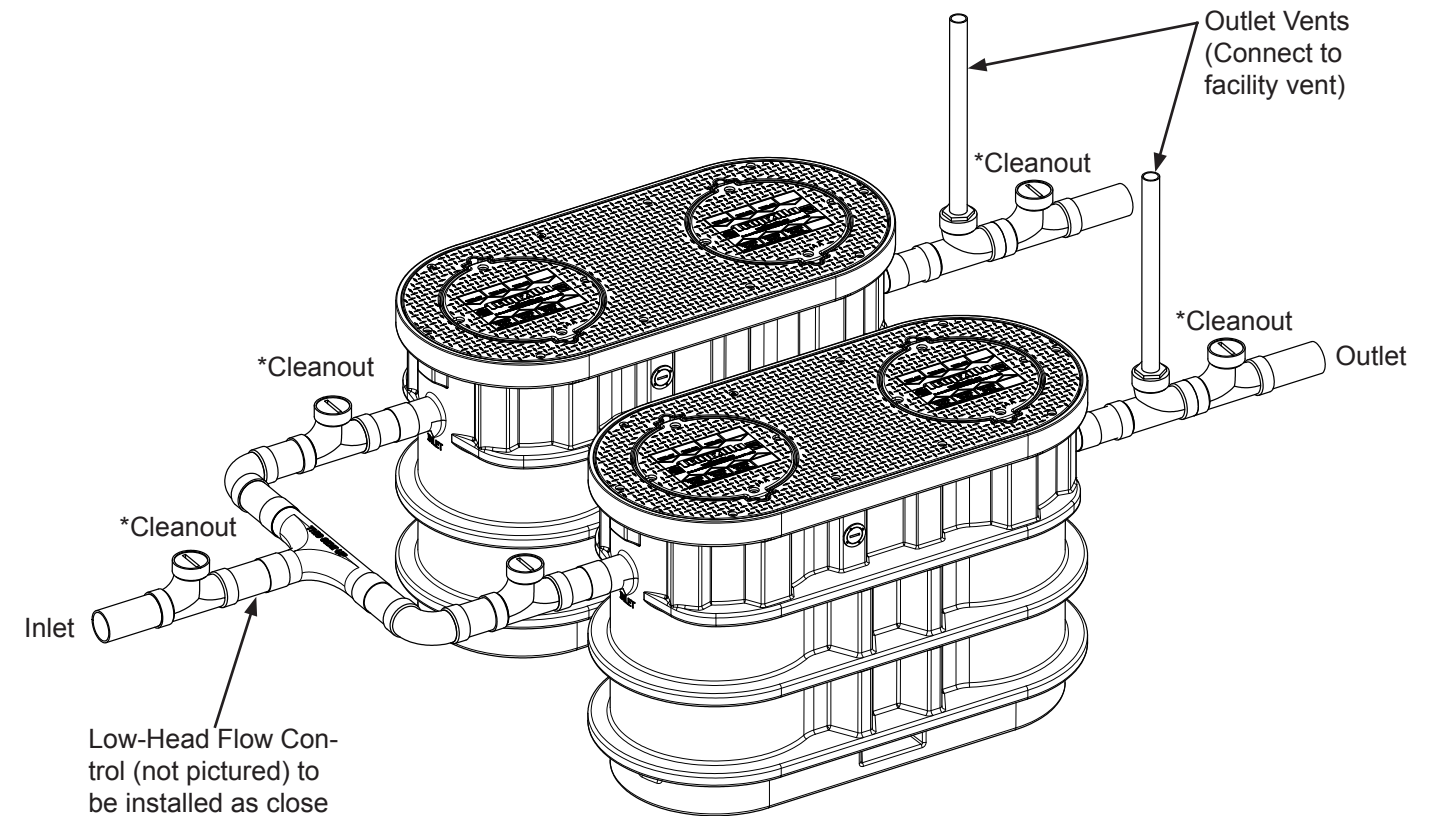

*Use a Two-Way Cleanout before and after all Trapzilla Installations

Note: Drawing for reference only. Equipment must be installed in compliance with all applicable laws, regulations and codes, including plumbing codes. Installation should be performed by a qualified plumber.

3.3.3 Installing Multiple Trapzilla Units in Series

Alternatively, two Trapzilla Grease Interceptors, Solids Separators or a combination may be installed in series. A single Trapzilla Solids Separator and Trapzilla Grease Interceptor should always be installed in series. Place Two-Way Cleanouts before, between and after the units as shown below. Make sure to connect an outlet vent after the Trapzilla Grease Interceptor. A Low Head Flow Control (LHFC) is shipped with each grease interceptor and should only be installed after the first Cleanout and before the first grease interceptor.

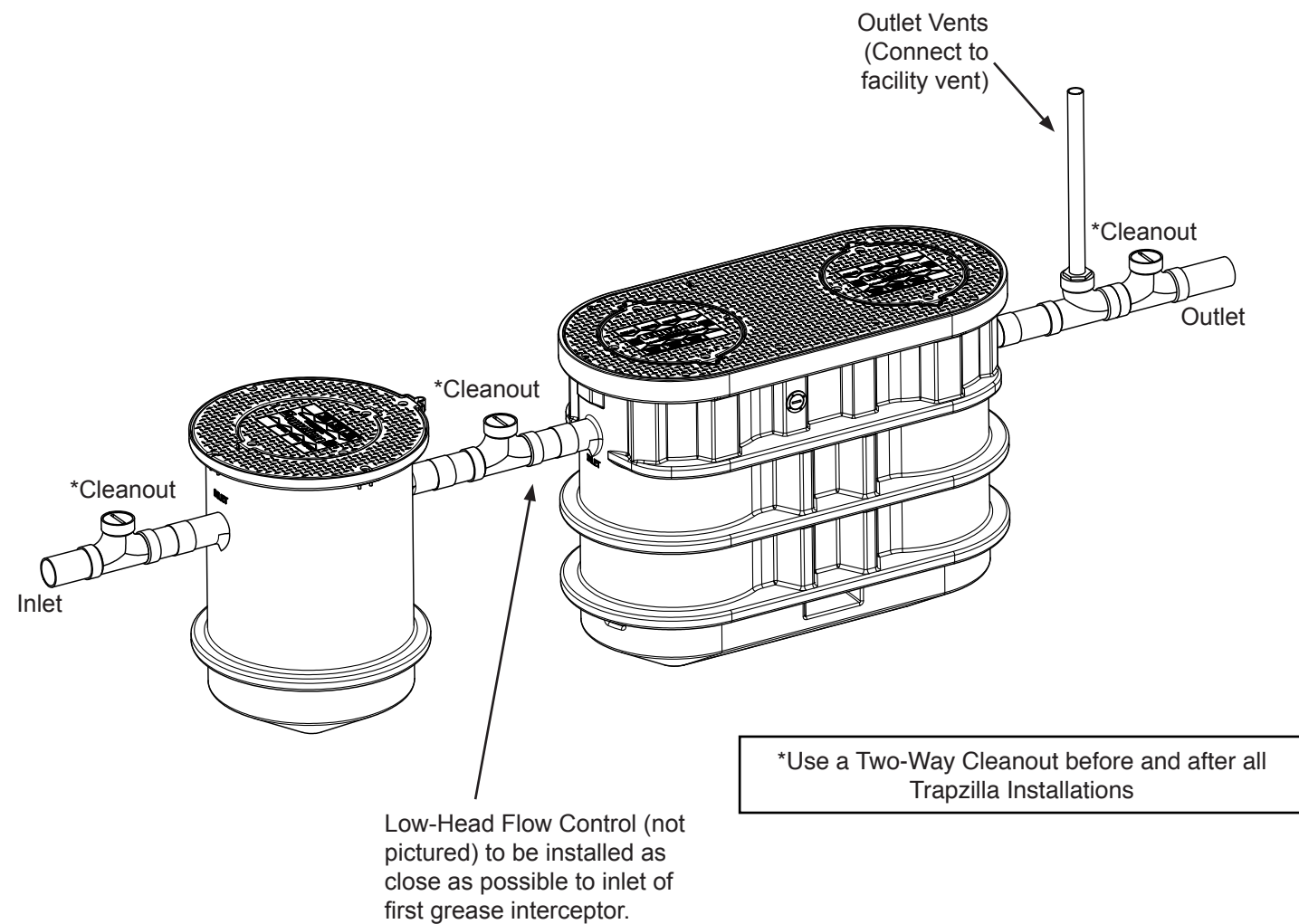

4. Above-Ground Installation

4.1 Components for Above-Ground Installations

Using a model-specific Support Stand, a Trapzilla unit may be installed directly on top of the floor in a location such as a basement or mechanical room.

TZ-1826-SSA comes with SSA-1826 and external brace for above-ground installations. All TZ-1826 units come with built-in 18" Risers which must be cut down and secured in field.

The External Brace must be installed in above-ground installations or the warranty will be voided.

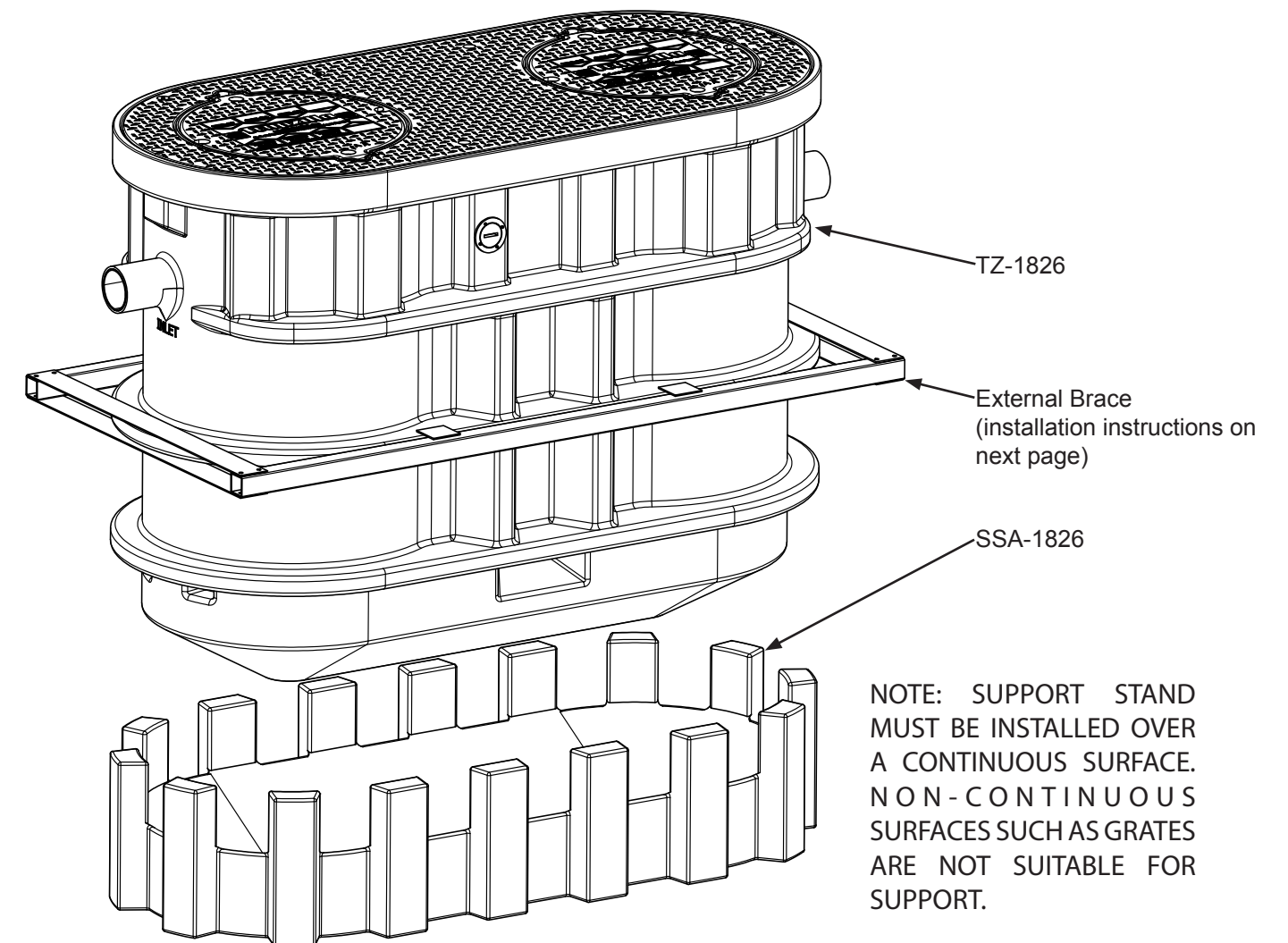

The SSA-1826 Support Stand is a one-piece assembly with a conical center that sits on the floor. It does not add appreciable height to the assembly.

Note: Drawing for reference only. Equipment must be installed in compliance with all applicable laws, regulations and codes, including plumbing codes. Installation should be performed by a qualified plumber.

4.2 Instructions for Assembling and Attaching External Brace

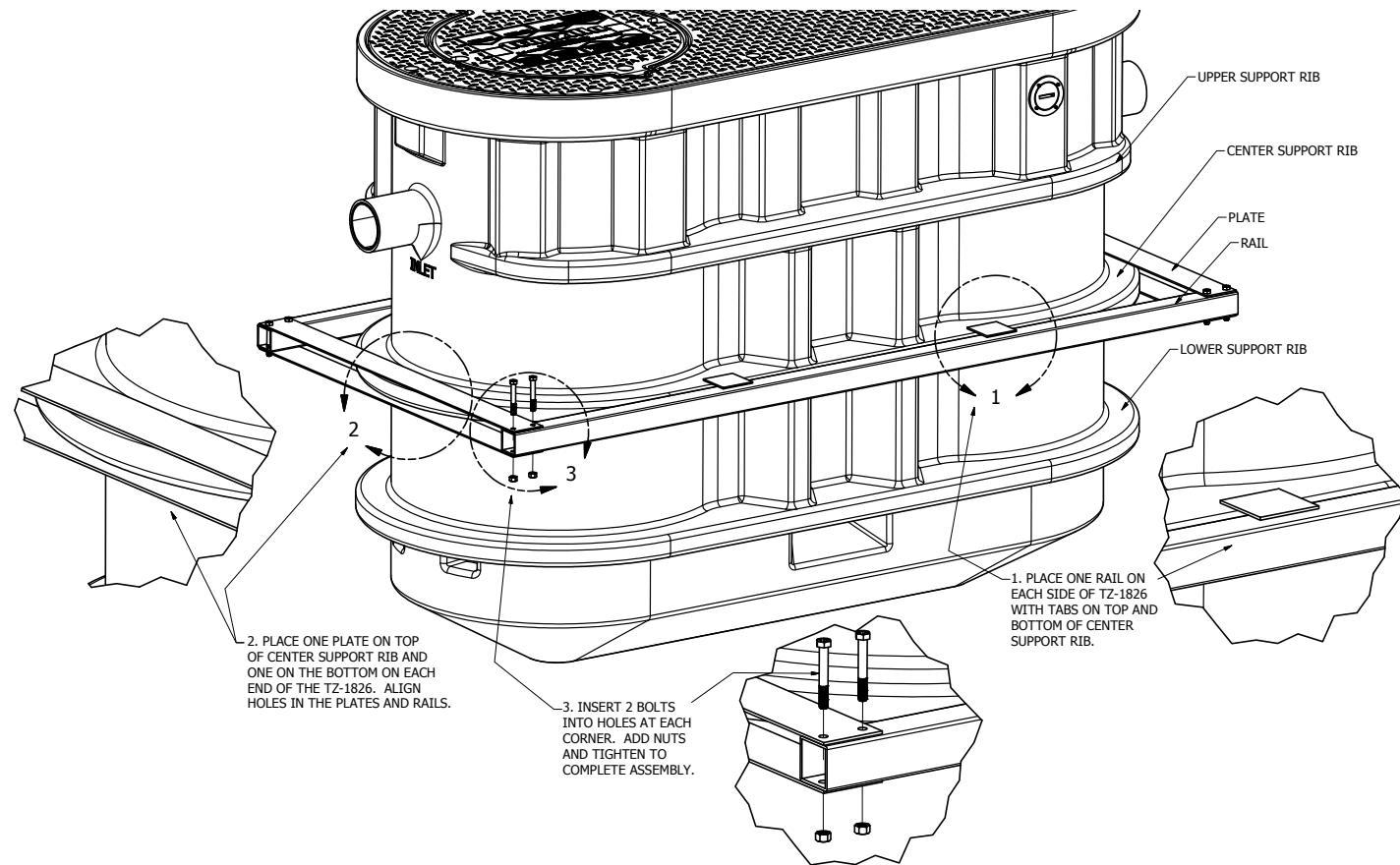

4.3.2 Construction of Riser for TSS-95-SSA installation in series with TZ-1826-SSA

For the installation of a TSS-95-SSA prior to the TZ-1826-SSA, a riser must be constructed to raise the smaller unit by 8" and provide full support for the weight of the interceptor and its contents.

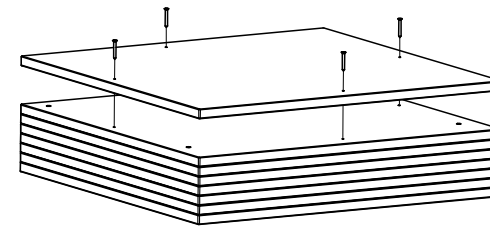

PLYWOOD STACK RISER
ASSEMBLE SHEETS OF PRESSURE TREATED PLYWOOD (MINIMUM 36 INCHES [92CM] SQUARE) TO THE DESIRED HEIGHT. SECURE EACH LAYER TO THE ONE BELOW WITH CORROSION RESISTANT SCREWS.

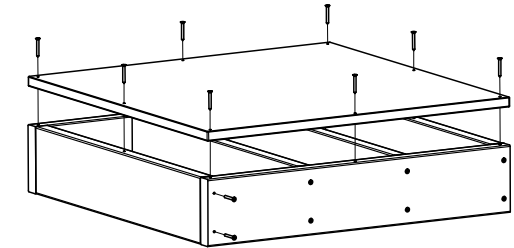

FRAMED FLOOR RISER
CONSTRUCT A FLOOR SUPPORT FRAME (MINIMUM 36 INCHES [92CM] SQUARE) FROM PRESSURE TREATED LUMBER OF 2 IN [50MM] NOMINAL THICKNESS AND OF THE DESIRED HEIGHT. SPACE FRAME MEMBERS NO MORE THAN 10 IN [25CM] APART. COVER THIS STRUCTURE WITH PRESSURE TREATED PLYWOOD. SECURE ALL JOINTS WITH CORROSION RESISTANT SCREWS.

4.3.3 Installing Multiple TZ-1826-SSA in Series

When installing multiple Trapzilla units in series, the change in elevation from the inlet to the outlet of a unit requires that each preceding unit be installed 1.5" higher than the unit after it. For above-ground units, pressure treated plywood may be placed fully beneath the support stand to create the height difference.

All installations inside of a building must have a vessel vent installed and be piped to atmosphere.

4.3 Instructions for Installing Multiple Trapzilla Units Above-Ground

4.3.1 Installing TZ-1826-SSA with TSS-95-SSA in Series

When installing a TZ-1826-SSA Interceptor with a TSS-95-SSA Solids Interceptor in series, the change in elevation from the outlet of one of these smaller units to the inlet of the TZ-1826-SSA to the requires that the preceding unit be installed 8" higher than the unit after it.

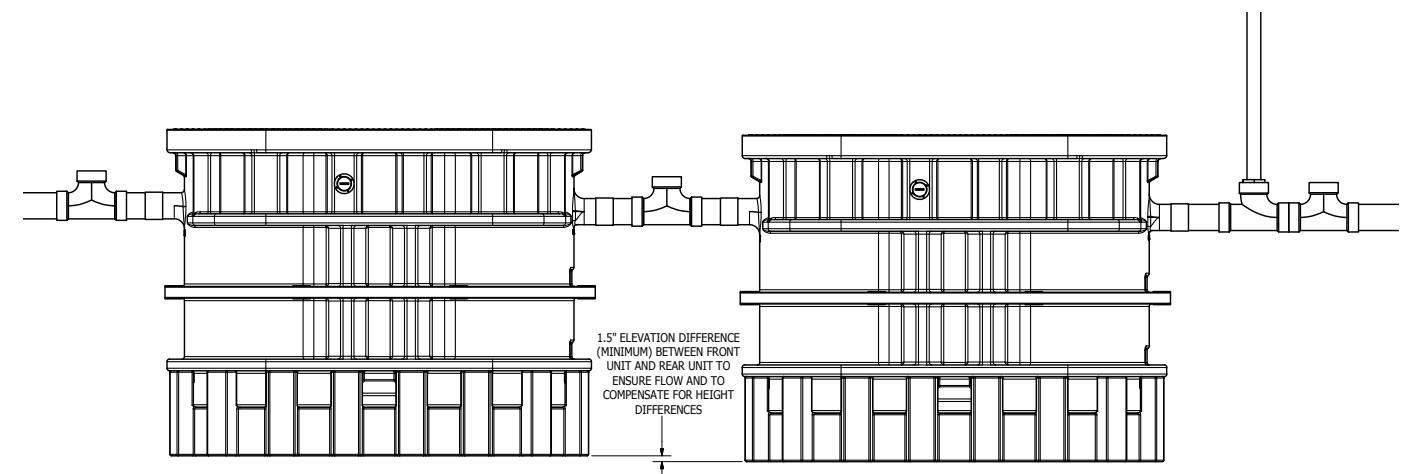
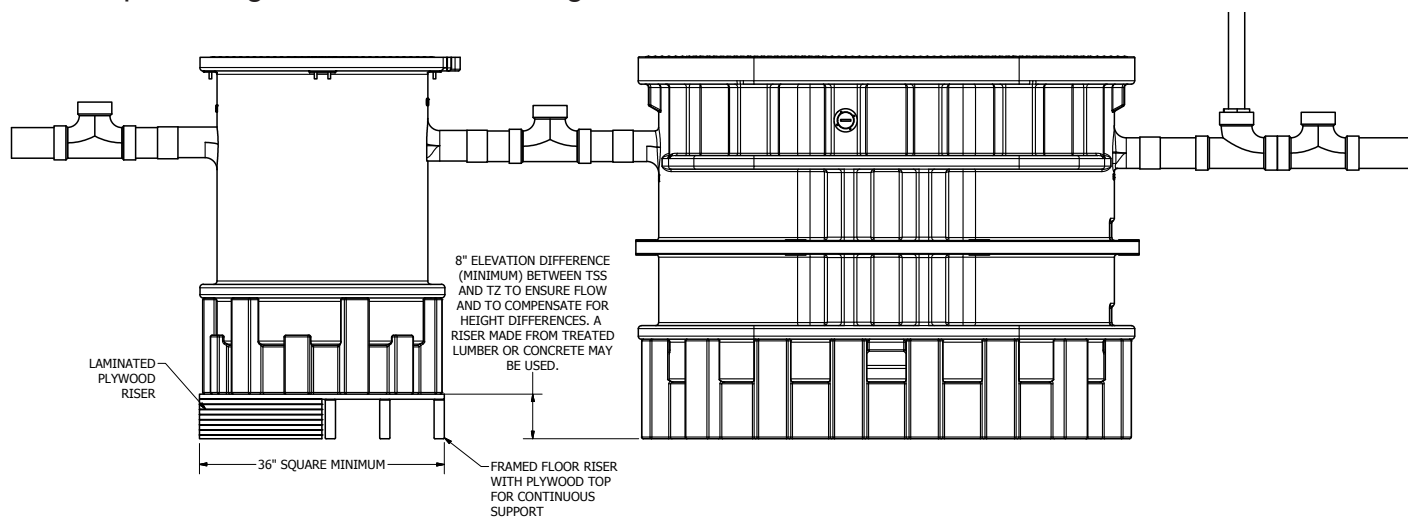

Note: Drawing for reference only. Equipment must be installed in compliance with all applicable laws, regulations and codes, including plumbing codes. Installation should be performed by a qualified plumber.

4.3.4 Installation of Pipe Hangers with Above-Ground Units

Trapzilla units installed indoors, above-ground require the use of pipe hangers (purchased separately) to properly support plumbing and reduce stress on connections with unit. Thermaco recommends the use of four (4) Zinc-plated Steel Loop Style hangers with 1000 lbs. work load limit for a single Trapzilla installation with two (2) hangers placed before inlet side cleanout and two (2) hangers placed after final cleanout.

Place each pair of hangers 35" apart (space-permitting) and no closer than 5" from any joint. When multiple units are installed place one (1) additional pipe hanger in between each unit, leaving 5" distance from unit and cleanout. Follow pipe hanger manufacturer's instructions for physical installation.

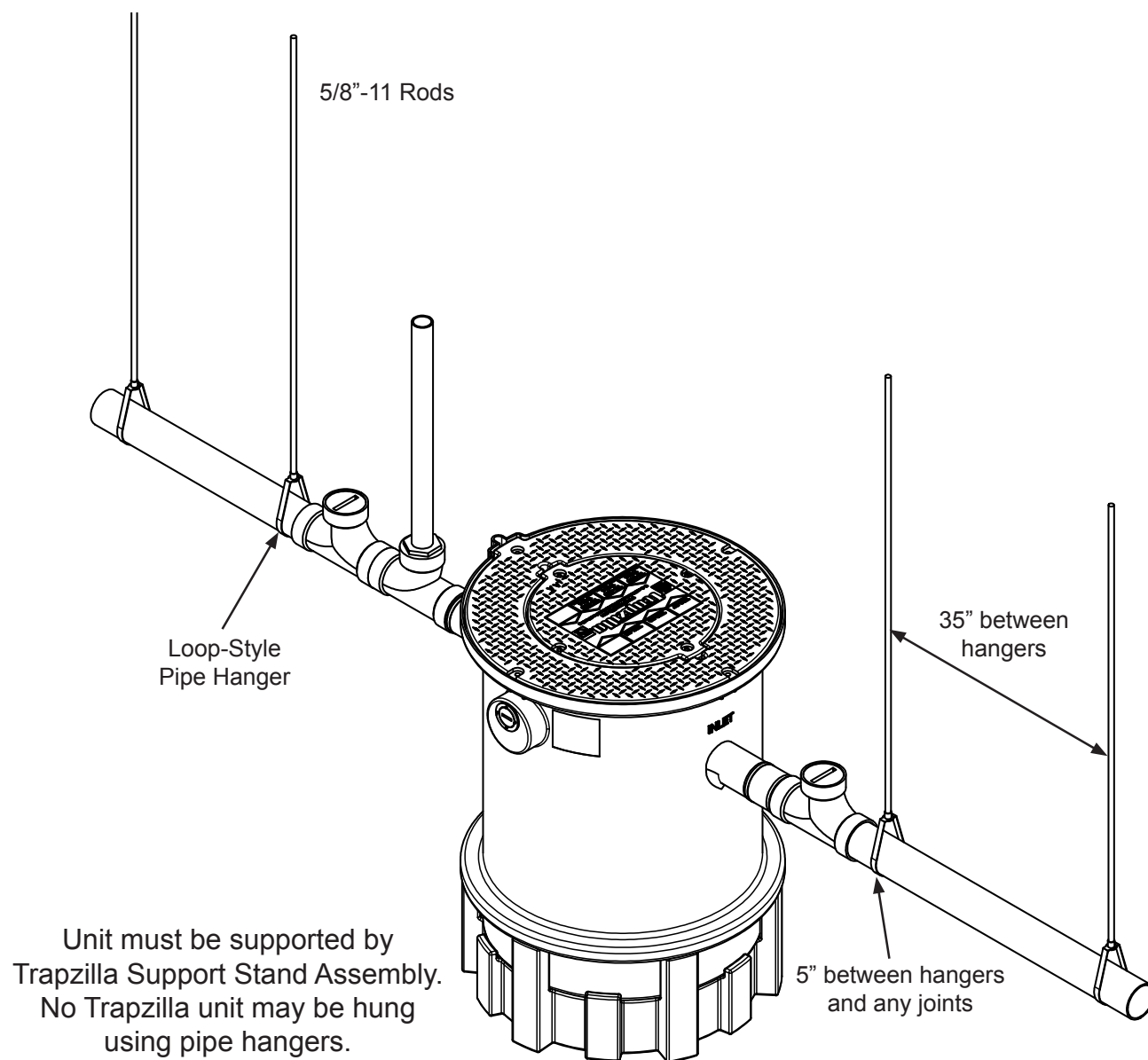

Note: Drawing for reference only. Equipment must be installed in compliance with all applicable laws, regulations and codes, including plumbing codes. Installation should be performed by a qualified plumber.

5. In-Ground Installation Instructions

5.1 Plumbing Instructions for Single TZ-1826 Installed In-Ground

A Trapzilla unit may also be installed in the ground inside or outside of the facility. For instances where the facility drainage piping requires an extension collar that is more than the 18" provided by the built-in extension, the ECA-TZ-29 Extension Collar Assembly may be installed to align the Trapzilla inlet with the drainage piping. Thermaco, Inc. strongly recommends surrounding the in-ground Trapzilla with concrete to provide additional structural strength and to offset buoyancy effects. For Buoyancy Calculations & suggested concrete fill quantities please see page 17.

In-Ground Installations inside of a building must have a vessel vent installed and be piped to atmosphere.

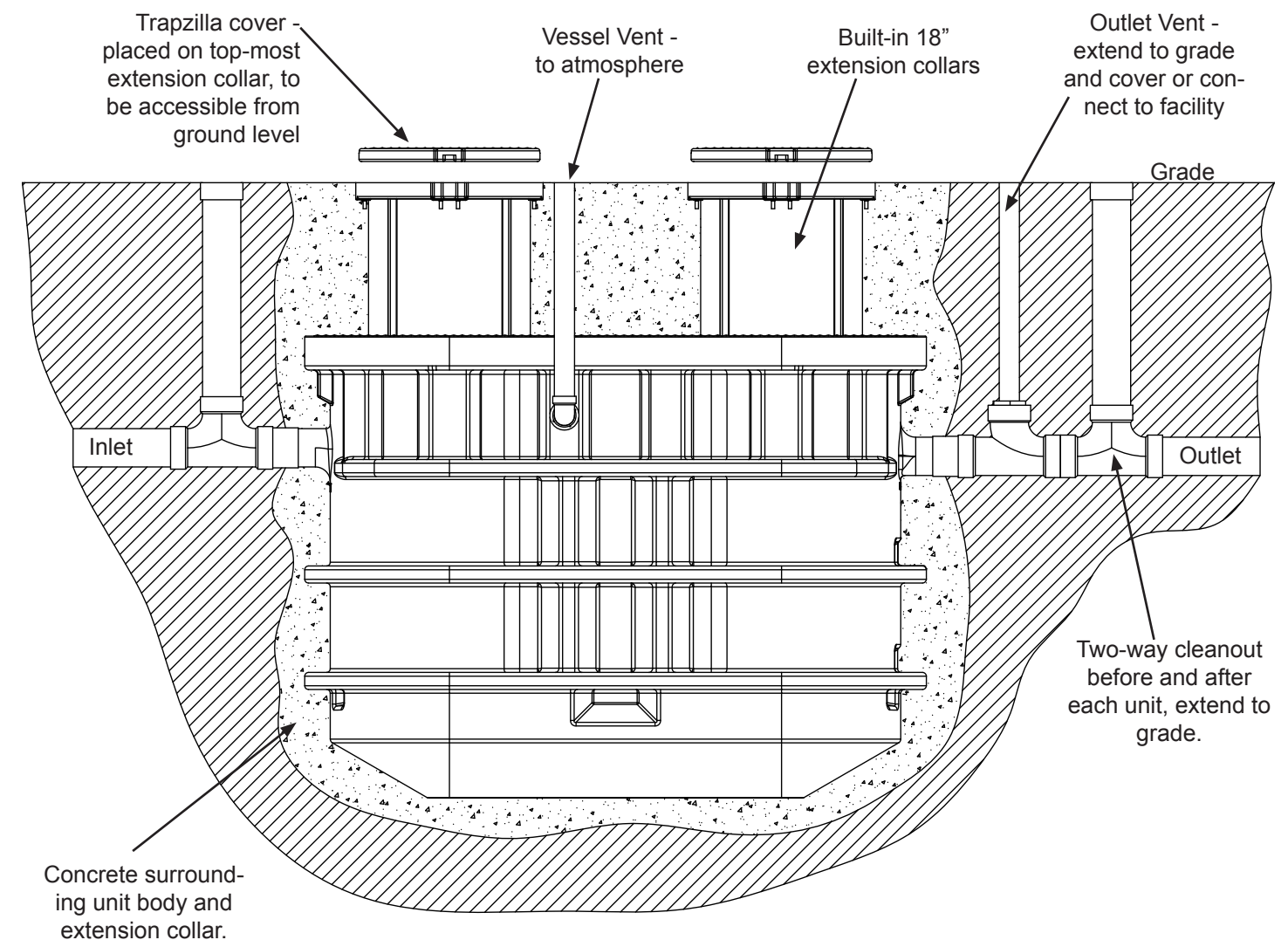

5.2 Plumbing Instructions for TZ-1826 with Optional ECA-TZ-29 Extension Collars (purchased separately)

In some cases, TZ-1826 may be installed in locations where built-in extension collar will not reach grade. In these cases, the two-piece ECA-TZ-29 Extension Collar (purchased separately) may be used to make lid accessible at ground level. Follow instructions included in ECA-TZ-29 packaging for installations. Each TZ-1826 would require two (2) ECA-TZ-29 if pipe depth requires.

*** In-ground installation instructions only applicable for units installed where center of outlet pipe is no more than 60" below grade. For all installations deeper than this, Thermaco must be contacted to verify site conditions and provide further instructions for proper installation. Failure to abide by this instruction will result in voiding the warranty of the unit.**

In-Ground Installations inside of a building must have a vessel vent installed and piped to atmosphere.

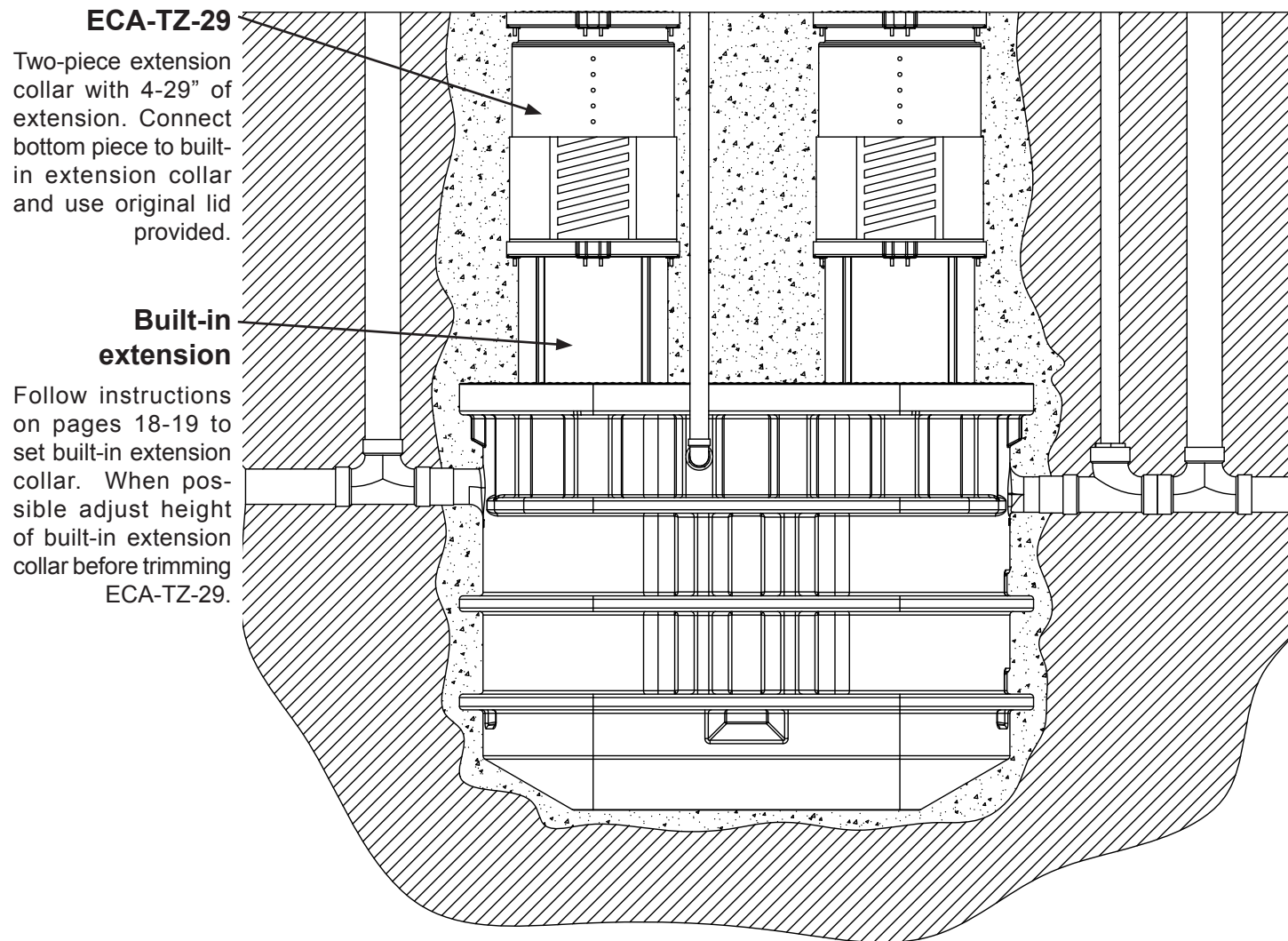

Note: Drawing for reference only. Equipment must be installed in compliance with all applicable laws, regulations and codes, including plumbing codes. Installation should be performed by a qualified plumber.

5.3 Concrete Specifications for In-Ground Installation

In order to offset the effects of buoyancy caused by groundwater (high water tables), strengthen the side load of the unit, and prevent movement of the unit in the event of shifting earth, Thermaco, Inc. recommends concrete be poured around the entirety of Trapzilla® units installed in-ground in the amounts of concrete specified in the table below. The concrete must be poured continuously and completely surrounding the Trapzilla® body (and Extension Collars if applicable) to ensure proper strength and security at a compression strength of 4000 psi (C28/35).

5.4 Concrete Calculations for TZ-1826 Models/Components*

Trapzilla Model	Amount of Concrete	
	Weight in lbs. (Kg)	Volume in Cubic Yards (m ³)
TZ-1826	3950	1.0
ECA-TZ-29 (each)	600	0.20

5.5 Trimming and Setting the ECA-TZ-18 Single-Piece Extension Collar

In-Ground Trapzilla Models ship with a built-in, single-piece, 18" extension collar that must be trimmed and then set to the correct height to bring the Solid Top Cover to grade.

Follow the steps below to set the extension collar prior to backfilling the hole with concrete.

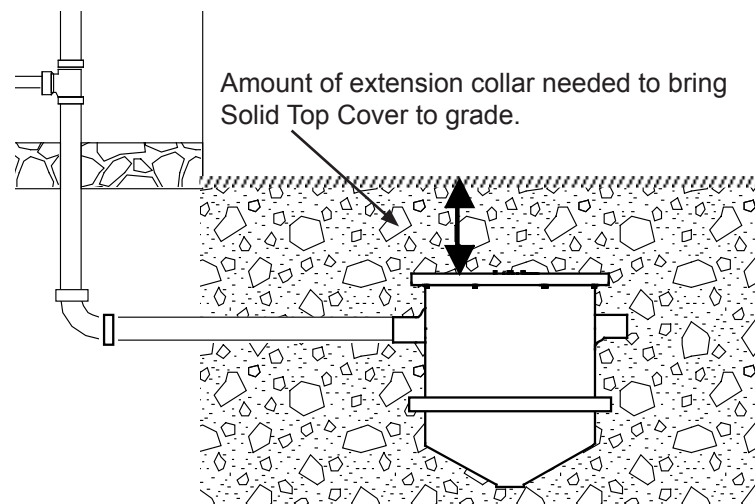

Step 1: With the Trapzilla unit installed in its permanent location, raise the telescoping extension collar to finished grade or floor level. Measure the height from the top of the unit to this finished extension collar height and record this dimension.

Note: If the floor will have a tile covering, allow for the tile thickness when determining the extension collar height.

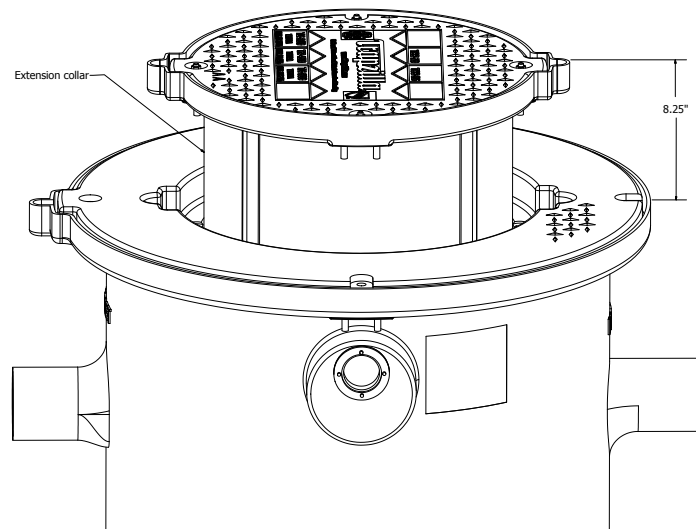

Step 2: Remove the extension collar adapter ring from the unit with the extension collar still in place. On the underside of the cover, mark the excess extension collar length at the bottom of the four (4) "skirt" portions of the adapter ring. Check the extension collar height dimension frequently during this marking to ensure that the collar has not moved. Extend this mark between the gaps in the "skirt" so that the collar is marked all around.

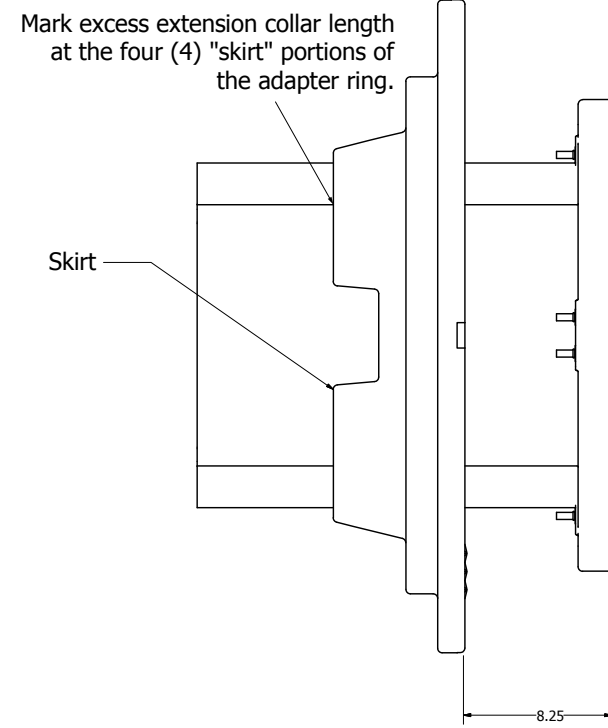

Step 3: Remove the extension collar from the adapter ring and, with an appropriate saw, cut along the line created in Step 2 to remove the excessive extension collar.

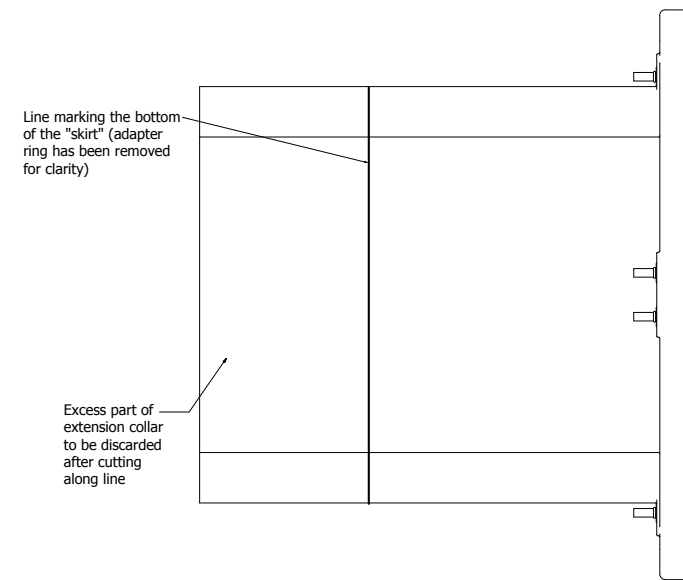

Step 4: Reinsert the extension collar into the adapter ring ensuring that the cover alignment key on the extension collar is aligned with its recess in the adapter ring. Reset the extension collar height to the dimension determined in Step 1.

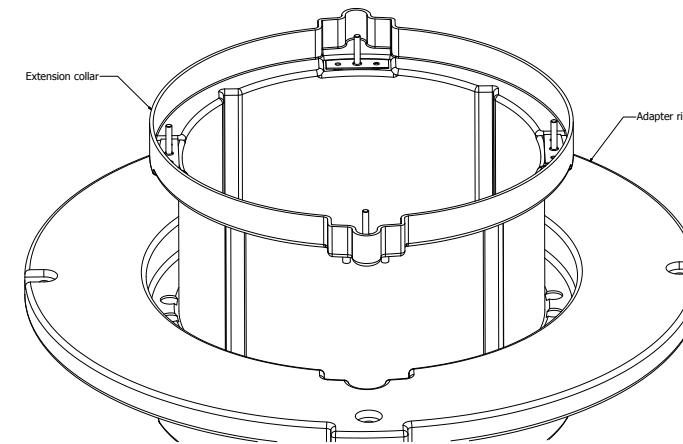

Step 5: Working from the bottom of the assembly, install eight (8) self-drilling, self-tapping screws (provided) through the extension collar wall and into the adapter ring. Two of these screws should be installed in each of the four (4) skirt areas of the adapter ring. Check the extension collar height dimension frequently during this operation to ensure that the collar has not moved. Note: Use caution when tightening these screws to ensure that they do not strip.

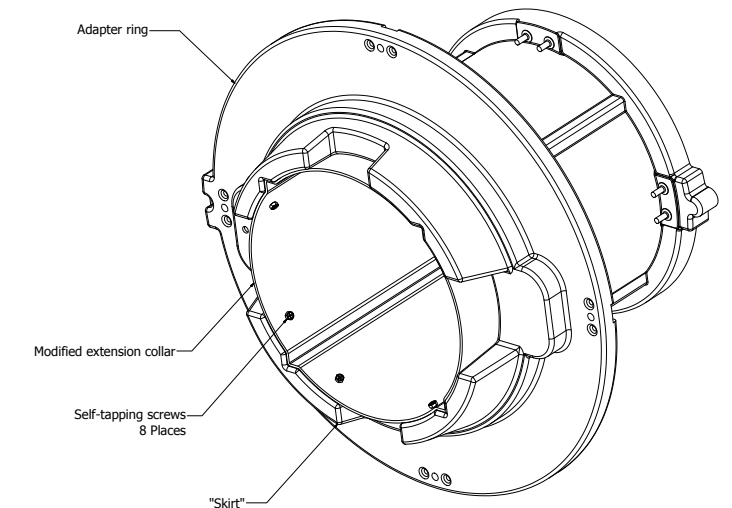

Step 6: Place the adapter ring/extension collar assembly onto the Trapzilla unit. Position the small cover onto the extension collar. Secure the adapter ring and the small cover with the brass nuts and flat washers provided. Seal the gap between the 18" extension collar and extension collar adapter ring using a silicone sealant.

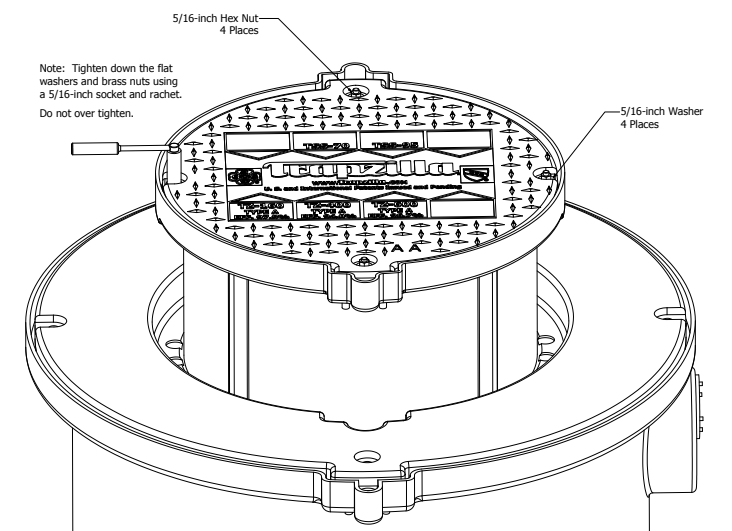

IMPORTANT: Excess extension collar must be trimmed on all units. Do not allow additional extension collar to extend beyond bottom of adapter ring. On units where extension collar is completely recessed, the extension collar should still be secured and the excess extension removed as in step 3.

Note: Drawing for reference only. Equipment must be installed in compliance with all applicable laws, regulations and codes, including plumbing codes. Installation should be performed by a qualified plumber.

6. Unit Maintenance

6.1 Measuring Grease/Solids Levels

Due to its unique design, Trapzilla is capable of retaining high quantities of grease in a compact footprint. Therefore, unlike traditional interceptors, Trapzilla can hold an extraordinarily high percentage of its volume in grease without losing separation efficiency. To determine the current levels of grease/solids in your Trapzilla grease interceptor, follow the instructions below.

1. Remove four nuts/washers securing the 22" Solid Top Cover.
2. Place a grease/sludge dipstick into the center of the opening, making sure that it goes through the hole in the horizontal baffle.
3. Once the dipstick has found its natural resting place at the lowest point in the conical shaped bottom, take the measurement.
4. Remove dipstick and compare grease/sludge levels to the corresponding unit in the charts below.

	Grease		Solids	
	Total Capacity (depth):	Ready to pump at (depth):	Total Capacity (height):	Ready to pump at (height):
TZ-1826	25"	20"	13.5"	10.75"

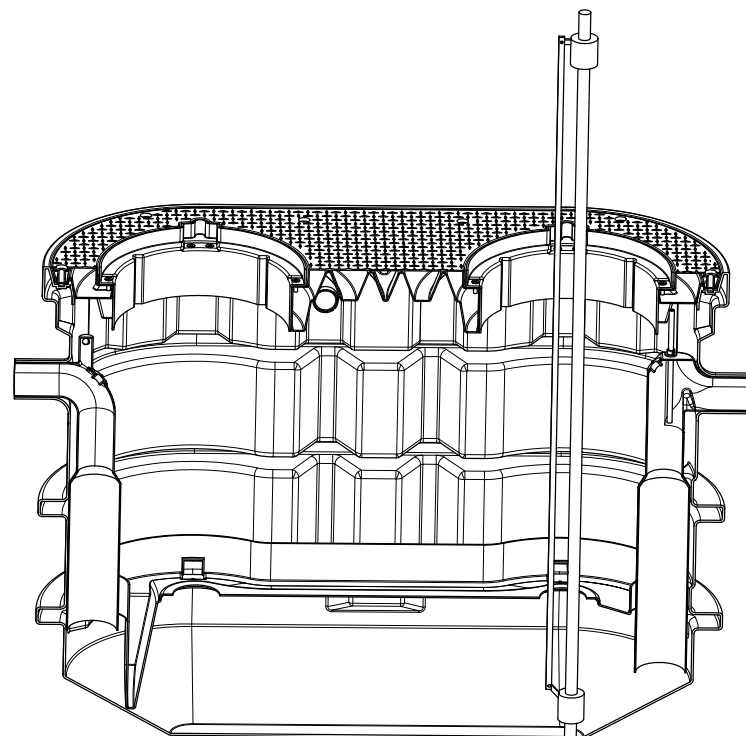

Take grease measurement from top of liquid level downward and compare to chart above.

Take solids/sludge measurement from bottom of unit upward and compare to chart above.

Note: Drawing for reference only. Equipment must be installed in compliance with all applicable laws, regulations and codes, including plumbing codes. Installation should be performed by a qualified plumber.

6.2 Pumping/Service Unit

Periodically, the Trapzilla® unit will need to be serviced which involves pumping out all accumulated grease and solids. Pumping frequency may be set at a regular interval by sewer district (every 30-90 days). If not, determine pumping frequency using instructions in 6.1 to periodically measure grease/solids levels to determine appropriate timing for pumping. Follow instructions below to pump/clean out TZ-1826.

1. Each lid has four brass nuts securing the lid. Remove the four brass nuts from the bolts and fully remove the 22" lid to pump out. It is not necessary to remove adapter lid to pump out Trapzilla.
2. Begin by taking the grease from the top of the main chamber until all grease is removed.
3. Upon reaching the horizontal baffle, you will see a hole through which you may access the rest of the grease and the solids. Be sure to lower the hose all the way to the bottom of the Trapzilla unit on the outlet side so that solids may be entirely removed. The conical shape and natural grade of the unit will allow solids and grease to run to outlet side of unit.
4. Have kitchen run water into unit to flush any remaining solids to the outlet end of the unit.
5. If necessary, use a water hose with spray nozzle to rinse off inside of unit.
6. Secure lids in place and instruct kitchen to run water into unit until full.

DO NOT use mechanical crust breaking devices to break down any mat that has formed inside the Trapzilla unit.

DO NOT use grinding augers in maintenance of the Trapzilla unit.

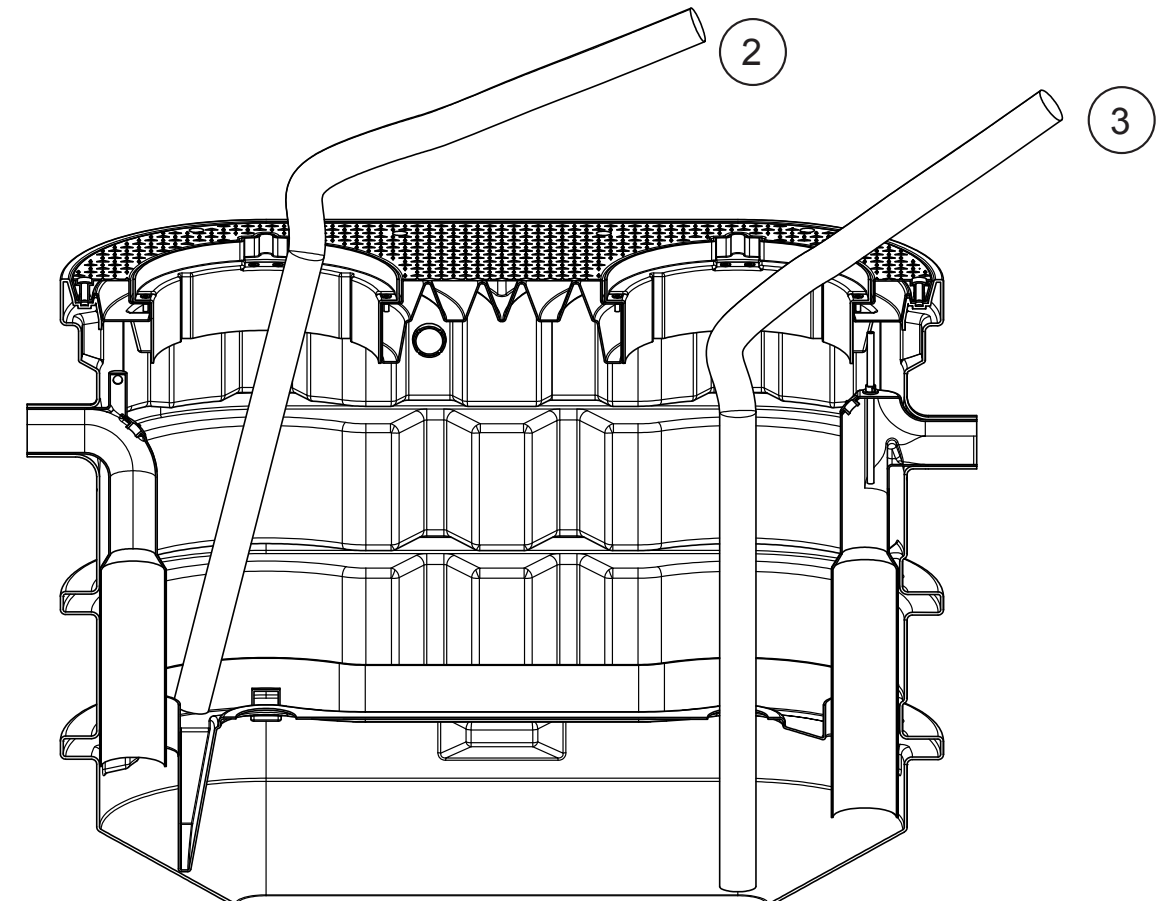



**Trapzilla99® Grease Interceptor
Installation and Operations Manual
TZ-1826 Models**

7. Limited Warranty and Remedy

Thermaco Incorporated warrants to the original user that the outer tank and inner tank components of the product manufactured by Thermaco and delivered with this warranty (the "Product") shall be free from material defects in workmanship and materials during the lifetime of the plumbing system in which the Product is initially installed. Notwithstanding the foregoing, this warranty shall not cover, and Thermaco shall have no obligation to repair or replace, any of the following component parts of the Product: lid, gaskets, brackets, nuts, and flow control.

Any and all warranty claims must be made in writing to Thermaco at 646 Greensboro Street, Asheboro, NC 27203 promptly after discovery of the defect giving rise to the warranty claim. Following and subject to Thermaco's preliminary approval of a warranty claim, the warranted Product must be delivered, prepaid, to Thermaco, together with proof of purchase and a return authorization number issued by Thermaco. If Thermaco determines that the Product is defective, the defect is covered by this warranty, and the warranty conditions are satisfied, Thermaco's sole obligation under this warranty, and the sole and exclusive remedy with respect to any such defect, is the repair or replacement, at Thermaco's option, of the defective equipment, component, or parts. Any replacements will be furnished F.O.B. point of shipment. Thermaco reserves the right to ship the user replacement parts with installation instructions. If Thermaco determines that the part, component, or the Product is not defective or that any condition of this warranty is not satisfied, then Thermaco shall have no obligation to repair or replace any such part, component, or the Product, and any costs associated with the return of such part, component, or the Product shall be borne by the party making the warranty claim.

This warranty shall not cover any defect in an otherwise covered Product resulting directly or indirectly from (and the occurrence of any of the following shall void any otherwise applicable warranty claim): (i) failure to install, operate or maintain the product in accordance with the Installation and Operation Manual that was included with the Product when it was sold and all other applicable Thermaco instructions and procedures, including, without limitation, use of mechanical crust breaking devices, use with grinding augers, use in excess of rated flow, use in excess of rated grease capacity, use to remove emulsified fats and oils or use that fails to comply with applicable laws, regulations or codes; (ii) damage in transit, handling or installation; (iii) modifications, adjustments, repairs, or alterations made by persons other than Thermaco representatives or certified plumbers; (iv) any change in the original installation or change to the original use of the Product; or (v) other causes not arising out of defects in workmanship or materials. Thermaco shall not be responsible for damage to products resulting from ultraviolet light exposure, floating of tank, vault flooding, sewer line back-up, pumping or lift station failure, ambient water flow, freezing, or other sources of water damage. This warranty does not cover equipment or parts not manufactured by Thermaco. Original user's costs relating to any service, adjustment, removal, repair, packing, or otherwise incurred with respect to the defect prior to submission for warranty are the responsibility of the original user. No distributor, sales person or other person is authorized to make any warranty statements on behalf of Thermaco regarding Thermaco products other than as set forth in this warranty. This statement of warranty supersedes and replaces any quote, brochure, or other statement or document with respect to warranty of the Product.

EXCEPT AS EXPRESSLY SET FORTH ABOVE, THERMACO MAKES NO REPRESENTATIONS, WARRANTIES OR GUARANTEES, EITHER EXPRESSED OR IMPLIED, INCLUDING, WITHOUT LIMITATION, AS TO MERCHANTABILITY OR FITNESS FOR A PARTICULAR PURPOSE, WHETHER OR NOT THERMACO HAD KNOWLEDGE OF PURCHASER'S PARTICULAR REQUIREMENTS OR NEEDS, OR WITH RESPECT TO ODOR GENERATION OR OTHER INCIDENTALS RELATING TO USE OF THE PRODUCT.

The sole and exclusive remedy with respect to this warranty or any other claim relating to defects or any other condition or use of Products, however caused, and whether such claim is based upon warranty, contract, tort, strict liability or any other theory, is LIMITED to the repair or replacement of the affected Product, component, or parts, in each case excluding labor or any other cost to remove or install the Product or, at Thermaco's sole option, refund of the original purchase price. IN NO EVENT SHALL THERMACO BE LIABLE, WHETHER IN CONTRACT, WARRANTY, TORT (INCLUDING NEGLIGENCE), STRICT LIABILITY, INDEMNITY OR ANY OTHER LEGAL THEORY, FOR INCIDENTAL OR CONSEQUENTIAL DAMAGES OR FOR ANY OTHER LOSS OR COST OF A SIMILAR TYPE. UNDER NO CIRCUMSTANCES WILL THE AGGREGATE LIABILITY OF THERMACO FOR ANY CAUSE OF ACTION RELATED TO THE PRODUCT COVERED HEREBY EXCEED THE NET PURCHASE PRICE RECEIVED BY THERMACO FOR THE PRODUCTS. This Warranty is made only for the benefit of the original user and is void upon any transfer of ownership or changes in installation. Note: Do not Pressure/Hydrostatic test our Products.